

J E T

JOVS-10

Oscillating Spindle Sander

708411M

230/50/1

PARTS LIST ERSATZTEILLISTE LISTE DE PIECES

Walter Meier (Tool) AG

Tämperlistrasse 5

CH-8117 Fällanden

Switzerland

Phone +41 44 806 47 48

Fax +41 44 806 47 58

jetinfo.eu@waltermeier.com

www.jettools.com



P-708411M 2010/06/25

Parts List for the JET JOVS-10

Oscillating Spindle Sander

Index No.	Part No.	Description	Size	Qty.
7.....	OVS10-007E.....	Power Cord.....		1
11.....	KEY5525.....	Key.....		1
18.....	OVS10-18.....	Oil Indicator.....		1
20.....	OS-30628.....	Oil Seal.....		1
21.....	BB-6206ZZ.....	Ball Bearing.....	6206ZZ	1
22.....	OVS10-022.....	C-Ring.....	RA63	1
22A.....	OVS10-022A.....	C-Ring.....	RA62	1
26.....	OVS10-026.....	Sleeve.....		1
27.....	OVS10-027.....	Guide Rail Shaft.....		1
28.....	BB-6205ZZ.....	Ball Bearing.....	6205LU	2
29.....	OVS10-029.....	Locking Nut.....		1
30.....	OVS10-030.....	Worm.....		1
31.....	OVS10-031.....	Spring Pin.....	5x30	1
32.....	OVS10-032.....	Main Shaft.....		1
33.....	KEY5550.....	Key.....	5x5x50	1
34.....	OVS10-034.....	Set Screw.....	M3x12	2
35.....	OVS10-035.....	Spur Gear.....		1
36.....	OVS10-036.....	Brass Bushing.....		2
37.....	TS-0208061.....	Socket Head Cap Screw.....	5/16"-18x1"	16
38.....	OVS10-038.....	Transmission Rod Shaft.....		2
39.....	OVS10-039.....	Transmission Rod.....		2
40.....	TS-0640091.....	Hex Nut, Nylon Lock.....	3/8"-16	4
47.....	OVS10-047E.....	Switch Cord.....		1
52.....	OVS10-052.....	Locking Nut.....	5/8"-11	1
55.....	OVS10-055.....	Rear Trunnion Bracket.....		2
56.....	TS-0208082.....	Socket Head Cap Screw.....	5/16"-24x1-1/2"	10
64.....	OVS10-064.....	Oil Lid.....		1
66.....	OVS10-066.....	Hex Socket Cap Screw.....	3/8"-16x3/4"	4
67.....	TS-0680042.....	Flat Washer.....	3/8"	8
86.....	OVS10-086.....	Angle Pointer.....		1
87.....	OVS10-087.....	Pan Head Machine Screw.....	10-24x1/4"	1
88.....	OVS10-088.....	Cap.....		1
89.....	OVS10-089.....	Nut.....	15/16"-24 R.H	2
134.....	JOVS10-134.....	Oil Plug.....	PT1/4"	1
135.....	JOVS10-135.....	Brass Bushing Bracket.....		1
136.....	JOVS10-136.....	Shaft Brass Bushing.....		4
137.....	JOVS10-137E.....	Pan Head Screw.....	5/16"-18x3/4"	1
139.....	JOVS10-139W.....	Bracket Base.....		2
140.....	TS-0680032.....	Flat Washer.....	5/16"	24
141.....	TS-0051021.....	Cap Screw.....	5/16"-18x5/8"	6
142.....	JOVS10-142E.....	Switch Box.....		1
144.....	JOVS10-144W.....	Vent Cover.....		1
145.....	JOVS10-145WE.....	Base.....		1
146.....	JOVS10-146.....	Motor Bracket.....		1
147.....	JOVS10-147E.....	Motor.....		1
.....	JOVS10-147MF.....	Motor Fan (not shown).....		1
.....	JOVS10-147MFC.....	Motor Fan Cover (not shown).....		1
.....	JOVS10-147CC.....	Capacitor Cover (not shown).....		1

Index No.	Part No.	Description	Size	Qty.
	JOVS10-147RC	Running Capacitor (not shown)	45uf, 250V	1
	JOVS10-147SC	Starting Capacitor (not shown)	300MFD, 125VAC	1
148	JOVS10-148E	Strain Relief Bushing		4
149	TS-0720081	Lock Washer	5/16"	20
151	JOVS10-151	Coupling Head		1
152	JOVS10-152	Tank		1
153	TS-0267041	Set Screw	1/4"-20x3/8"	2
154	JOVS10-154	Tank Lid		1
156	JOVS10-156W	Sanding Assembly Rack		2
158	JOVS10-158W	Rear Trunnion		2
159	JOVS10-159	Locking Knob	3/8"-16x3/4"	2
160	JOVS10-160W	Dust Cover		1
161	TS-0051061	Hex Bolt	5/16"-18x1-1/4"	2
162	TS-0561021	Hex Nut	5/16"-18	6
163	JOVS10-163W	Working Table		1
164	JOVS10-164	Scale		1
169	JOVS10-169	Fixed Rod		1
170	TS-0561031	Hex Nut	3/8"-16	2
171	JOVS10-171	Rubber Feet		4
172	JOVS10-172	Sinking Head Screw	5/16"-18x3/4"	4
174	JOVS10-174	JET Logo		1
177	JOVS10-177E	Pan Head Screw	3/16"-24x3/8"	2
178	JOVS10-178E	Switch		1
179	JOVS10-179	Spring Pin	3x22	1
180	JOVS10-180	Fiber Washer	3/8"	2
181	TS-0720091	Lock Washer	3/8"	4
182	TS-0271071	Set Screw	3/8"-16x3/4"	1
184	JOVS10-184E	I.D Label		1
185	JOVS10-185E	Motor Label		1
186	JOVS10-186	Rivet		4
187	TS-0267041	Set Screw	1/4"-20x3/8"	1
189	TS-0680011	Flat Washer	3/16"	1
190	TS-0267021	Set Screw	1/4"-20x1/4"	2
191	JOVS10-191E	Switch Cover		1
192	JOVS10-192E	Machine Screw		4
193	JOVS10-193E	Pan Head Screw	1/4"-20x3/8"	2
194	TS-0680021	Flat Washer	1/4"	4
195	TS-0561011	Nut	1/4"-20	2
196	JOVS10-196E	Direction Label		1

Sanding Assemblies

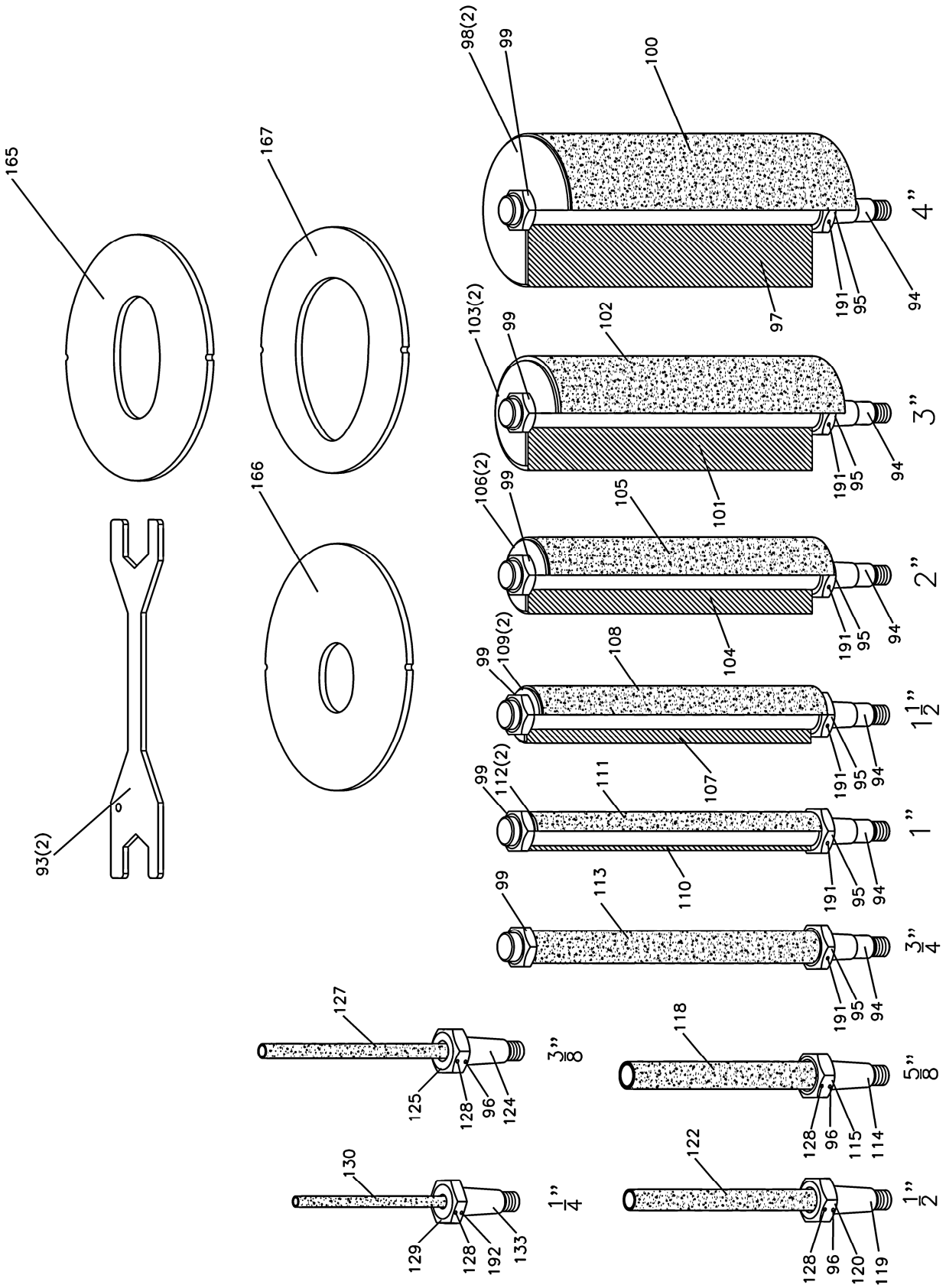

Sanding Assemblies

Index No.	Part No.	Description	Size	Qty.
93	OVS10-093	Wrench		2
94	OVS10-094A	Arbor	3/4"	6
95	OVS10-095	Hex Nut		6
96	OVS10-096	Spring Pin	3.5x25	3
97	30105000J	Spindle Assembly	4"	1
98	OVS10-098	Washer	4"	2
99	OVS10-099	Nut	3/4"-16"	6
100	575834	Sanding Sleeve (60 Grit)	4"	
	575835	Sanding Sleeve (80 Grit)	4"	
	575836	Sanding Sleeve (100 Grit)	4"	
101	30105000I	Spindle Assembly	3"	1
102	575830	Sanding Sleeve (60 Grit)	3"	
	575831	Sanding Sleeve (80 Grit)	3"	
	575832	Sanding Sleeve (100 Grit)	3"	
103	OVS10-103	Washer	3"	2
104	30105000H	Spindle Assembly	2"	1
105	575826	Sanding Sleeve (60 Grit)	2"	
	575827	Sanding Sleeve (80 Grit)	2"	
	575828	Sanding Sleeve (100 Grit)	2"	
106	OVS10-106	Washer	2"	2
107	30105000G	Spindle Assembly	1-1/2"	1
108	575822	Sanding Sleeve (60 Grit)	1-1/2"	
	575823	Sanding Sleeve (80 Grit)	1-1/2"	
	575824	Sanding Sleeve (100 Grit)	1-1/2"	
109	OVS10-109	Washer	1-1/2"	2
110	30105000F	Spindle Assembly	1"	1
111	575818	Sanding Sleeve (60 Grit)	1"	
	575819	Sanding Sleeve (80 Grit)	1"	
	575820	Sanding Sleeve (100 Grit)	1"	
112	OVS10-112	Washer	1"	2
113	575814	Sanding Sleeve (60 Grit)	3/4"	
	575815	Sanding Sleeve (80 Grit)	3/4"	
	575816	Sanding Sleeve (100 Grit)	3/4"	
114	OVS10-114A	Arbor	5/8"	1
115	OVS10-115	Hex Nut		1
118	575810	Sanding Sleeve (60 Grit)	5/8"	
	575811	Sanding Sleeve (80 Grit)	5/8"	
	575812	Sanding Sleeve (100 Grit)	5/8"	
	575813	Sanding Sleeve (120 Grit)	5/8"	
119	OVS10-119A	Arbor	1/2"	1
120	OVS10-120	Hex Nut		1
122	575806	Sanding Sleeve (60 Grit)	1/2"	
	575807	Sanding Sleeve (80 Grit)	1/2"	
	575808	Sanding Sleeve (100 Grit)	1/2"	
	575809	Sanding Sleeve (120 Grit)	1/2"	
124	OVS10-124A	Arbor		1
125	OVS10-125	Hex Nut		1
127	575802	Sanding Sleeve (60 Grit)	3/8"	
	575803	Sanding Sleeve (80 Grit)	3/8"	
	575804	Sanding Sleeve (100 Grit)	3/8"	
128	OVS10-117	Set Screw	3/16"-24x1/4"	4
129	OVS10-129	Arbor		1

Index No.	Part No.	Description	Size	Qty.
130	575800	Sanding Sleeve (100 Grit)	1/4"	1
	575801	Sanding Sleeve (120 Grit)	1/4"	1
133	OVS10-133A	Spindle		1
165	JOVS10-165	Table Insert (medium)		1
166	JOVS10-166	Table Insert (small)		1
167	JOVS10-167	Table Insert (Large)		1
191	JOVS10-191	Spring Pin	5x25	6
192	JOVS10-192	Spring Pin	3x25	1
197	JOVS10-197E	Table Insert (no show)	3/8"	1
198	JOVS10-198E	Table Insert (no show)	2"	1
199	JOVS10-199E	Table Insert (no show)	4"	1

**JOVS-10
708411M**

230/50/1

	colour of strands	Litzenfarben	couleur des cordons
BK	black	schwarz	noir
WH	white	weiß	blanc
BU	blue	blau	bleu
YE	yellow	gelb	jaune
RD	red	rot	rouge
BN	brown	braun	brun
GY	grey	grau	gris
GNYE	green-yellow	grün-gelb	vert-jaune
OG	orange	orange	orange
VT	violet	violett	violet

	meaning of symbol	Bedeutung der Zeichen	interprétation
M	motor	Motor	moteur
S	switch	Schalter	interrupteur
C	condenser	Kondensator	condensateur
E	electronic unit	Elektronik Einheit	unité électronique
F	fuse	Sicherung	fusible
RS	reversing switch	Drehrichtungsschalter	commu. droite/gauche
S	centrifugal switch	Fliehkraftschalter	déclencheur centrifuge
OL	overload cut-off	Überlastschuttschalter	déclencheur surcharge
LS	limit switch	Positionsendschalter	micro

