

JET

JCDC-1.5

Cyclone Dust Collector

JCDC-1.5.....717515M1~230V, 50Hz

PARTS LIST

JPW (Tool) AG
Tämperlistr. 5
CH-8117 Fällanden
Switzerland
Phone +41 44 806 47 48
Fax +41 44 806 47 58

www.jettools.com

P-717515M

2016-04



Parts Breakdown for JCDC-1.5 Cyclone Dust Collector

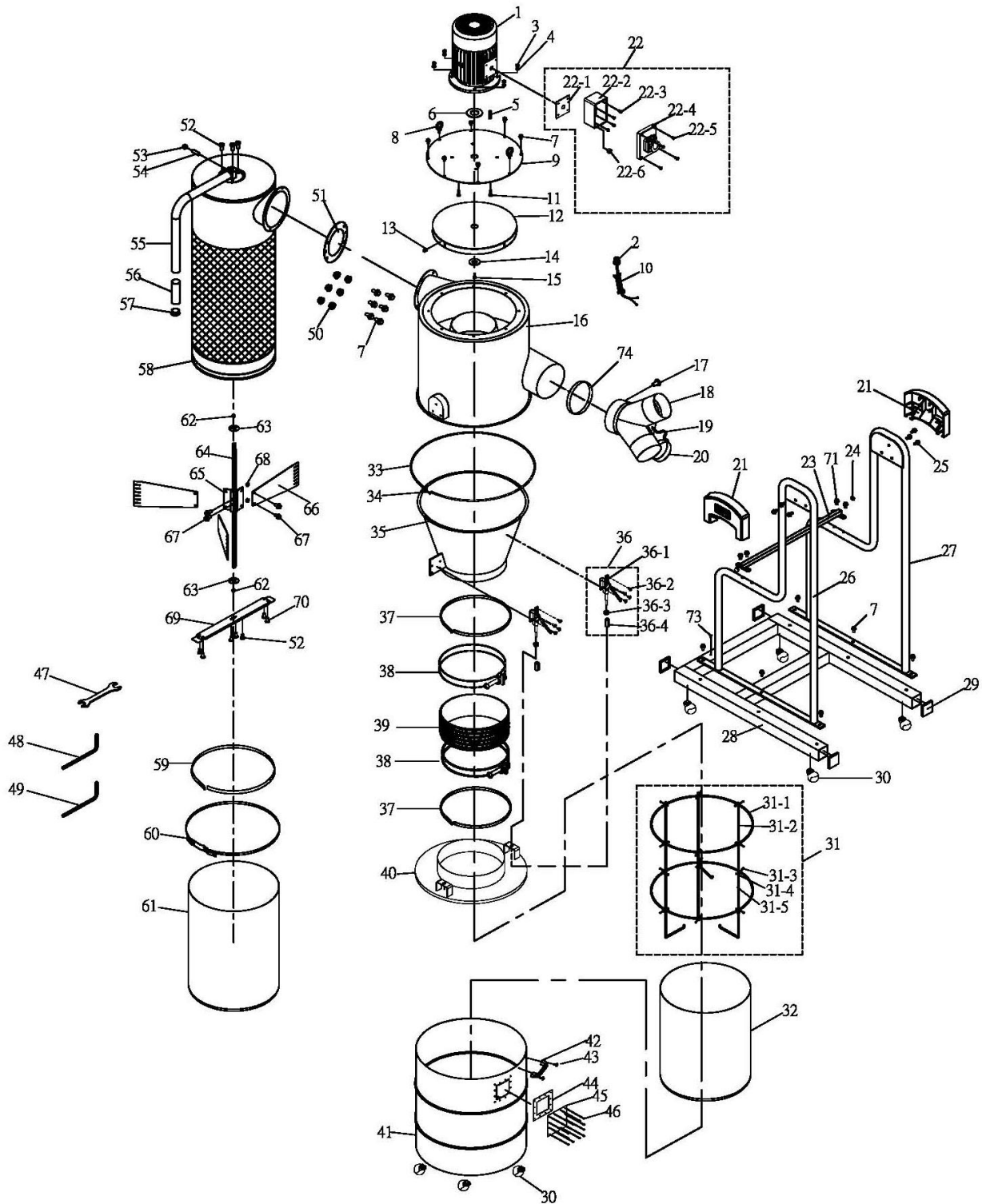

Parts List for JCDC-1.5 Cyclone Dust Collector

Index No.	Part No.	Description	Size	Qty.
1	502-A052	Motor	1½HP/230V/50HZ/1PH	1
	JCDC1.5-01SC	Start Capacitor (not shown)	300MFD, 125VAC	1
	JCDC1.5-01RC	Running Capacitor (not shown)	30uF, 250V	1
	JCDC1.5-01FC	Fan Cover (not shown)		1
	JCDC1.5-01CF	Cooling Fan (not shown)		1
	502-A052-CS	Centrifugal Switch (not shown)		1
2	516-A003	Strain Relief	MP-16	1
3	TS-0570021	Hex Nut	5/16"	4
4	TS-0720081	Lock Washer	5/16"	4
5	JCDC1.5-05	Key	6x6x25	1
6	JCDC1.5-06	Rubber Seal	Dia. 24mm	1
7	JCDC1.5-07	Hex Flange Head Screw	5/16" x 3/4"	18
8	JCDC1.5-08	Eye Bolt	5/16"	2
9	JCDC1.5-09	Motor Plate		1
10	503-K106	Power Cord w/ 1PH CE Plug	1.0mm ² x 3Cx2.8M	1
	503-L040	Power Cord w/ BS Plug (UK)	1.5mm ² x 3Cx3M	1
11	TS-0051051	Hex Cap Screw	5/16" x 1"	4
12	JCDC1.5-12	Impeller	Dia. 13"	1
13	TS-0270021	Socket Set Screw	5/16" x 5/16"	1
14	JCDC1.5-14	Lock Washer	Exclusive	1
15	JCDC1.5-15	Socket Head Cap Screw (Left Thread)	M6 x 20	1
16	JCDC1.5-16	Intake Barrel		1
17	5513357	Mach Screw, Pan HD, Phillips	3/16" x 3/8"	1
18A	JCDC1.5-18A	Inlet Adaptor Assembly (includes #18 thru 20)	6" x (2) 4"	1
18	JCDC1.5-18	Inlet Adaptor	6" x (2) 4"	1
19	JCDC1.5-19	Chain		1
20	JCDC1.5-20	Inlet Adaptor Cap	4"	1
21	JCDC1.5-21	Side Cap	1"	2
22	501-D005	Switch Assembly (# 22-1 thru 22-6)		1
22-1	501-D005-22-1	Switch Packing		1
22-2	501-D005-22-2	Switch Box		1
22-3	501-D005-22-3	Phillips Head Screw	3/16"x3/8"	4
22-4	501-D005-22-4	CE On / Off Switch (230V/1PH)	KJD-12	1
22-5	501-D005-22-5	Tapping Screw		4
22-6	501-D005-22-6	Plastic Nut	MP-16	1
23	JCDC1.5-23	Connecting Square Tube	19 x 19 x 517	1
24	JCDC1.5-24	Tube Plug	19 x 19	2
25	JCDC1.5-25	Hex Flange Head Screw	5/16" x 1/2"	6
26	JCDC1.5-26	Stand-Left		1
27	JCDC1.5-27	Stand-Right		1
28	JCDC1.5-28	Base		1
29	JCDC1.5-29	Tube Plug	30 x 30	4
30	JCDC1.5-30	Swivel Caster	3/8"	8
31	JCDC1.5-31	Bag Frame Kit (#31-1 thru 31-5)		1
31-1	JCDC1.5-31-1	Hoop	6T	2
31-2	JCDC1.5-31-2	Bag Frame Support - Long	7mm	3
31-3	TS-1540011	Hex Nut	M3	12
31-4	JWL1221VS-314	Mach Screw, Pan HD, Phillips	M3 x 12	12
31-5	JCDC1.5-31-5	Bag Frame Support -Short	7mm	3

32	717516	Drum Collection Bag for JCDC-1.5 (pkg. of 5)	700 x 660 /mm	1
33	JCDC1.5-33	Clamp	Dia. 420 mm	1
34	TS-0050111	Hex Cap Screw	1/4" x 2-1/2"	1
35	JCDC1.5-35	Cyclone Funnel		1
36	JCDC1.5-36	Quick Lever Assembly (# 36-1 thru 36-4)		2
36-1	JCDC1.5-36-1	Quick Lever		2
36-2	5712561	Mach Screw, Pan HD, Phillips	M5 x 8	8
36-3	TS-0570031	Hex Nut	3/8"	2
36-4	JCDC1.5-36-4	Long Nut	3/8"	2
37	JCDC1.5-37	Foam Tape	L810 x W30 x T1 /mm	2
38	JCDC1.5-38	Hose Clamp	10-1/2"	2
39	JCDC1.5-39	Hose	Dia. 10"	1
40	JCDC1.5-40	Collection Drum Lid		1
41A	JCDC1.5-41A	Collection Drum Assembly (#30,41 thru 46)		1
41	JCDC1.5-41	Collection Drum		1
42	JCDC1.5-42	Handle		1
43	TS-081F031	Mach Screw, Flat HD, Phillips	1/4" x 1/2"	2
44	JCDC1.5-44	Rubber Pad		1
45	JCDC1.5-45	PC Plate		1
46	JCDC1.5-46	Rivet	4-2	12
47	SWSS3-201	Open End Wrench	10-12 mm	1
48	TS-152705	Hex Wrench	4mm	1
49	TS-152706	Hex Wrench	5mm	1
50	TS-0561021	Hex Nut	5/16"	6
51	JCDC1.5-51	Gasket		1
52	JCDC1.5-52	Socket HD Button Screw	M5 x 6	6
53	TS-0561021	Hex Nut	5/16"	1
54	TS-0270071	Socket Set Screw	5/16" x 3/4"	1
55A	JCDC1.5-55A	Handle Assembly (#55,56,57)		1
55	JCDC1.5-55	Handle		1
56	JCDC1.5-56	Grip		1
57	JCDC1.5-57	Pipe Plug		1
58	JCDC1.5-58	Canister Filter		1
59	JCDC1.5-59	Foam Tape	L1265 x W20 x T3 /mm	1
60	JCDC1.5-60	Clamp		1
61	717511	Canister Collection Bag for JCDC (pkg. of 5)	600 x 500 /mm	1
62	JCDC1.5-62	Oil-Retaining Bearing		2
63	JCDC1.5-63	Bearing Cover		2
64	JCDC1.5-64	Shaft		1
65	JCDC1.5-65	Fixing Block		1
66A	JCDC1.5-66A	Scraper Assembly (#52,62 thru 70)		1
66	JCDC1.5-66	Scraper		3
67	TS-1481031	Hex Cap Screw	M5 x 12	8
68	TS-1540031	Hex Nut	M5	6
69	JCDC1.5-69	Support Plate		1
70	5712561	Mach Screw, Pan HD, Phillips	M5 x 8	4
71	JCDC1.5-71	Hex Flange Head Screw	1/4" x 1/2"	4
73	5711571	Mach Screw, Pan HD, Phillips	3/16" x 1/4"	1
74	JCDC1.5-74	Foam Tape	L490 x W30 x T1 /mm	1
	JCDC1.5-HP	Hardware Package (see sect. 5.2 for contents)		

