



JTSS-3200X2 **PANEL SAW**

JTSS-3200X2...10000062T...3~400V, 50Hz

PARTS LIST

JPW (Tool) AG
Ackerstrasse 45, CH-8610 Uster,
Switzerland

www.jettools.com

P-10000062T 2019-10

1.0 Exploded Drawing of Machine Cabinet Assembly

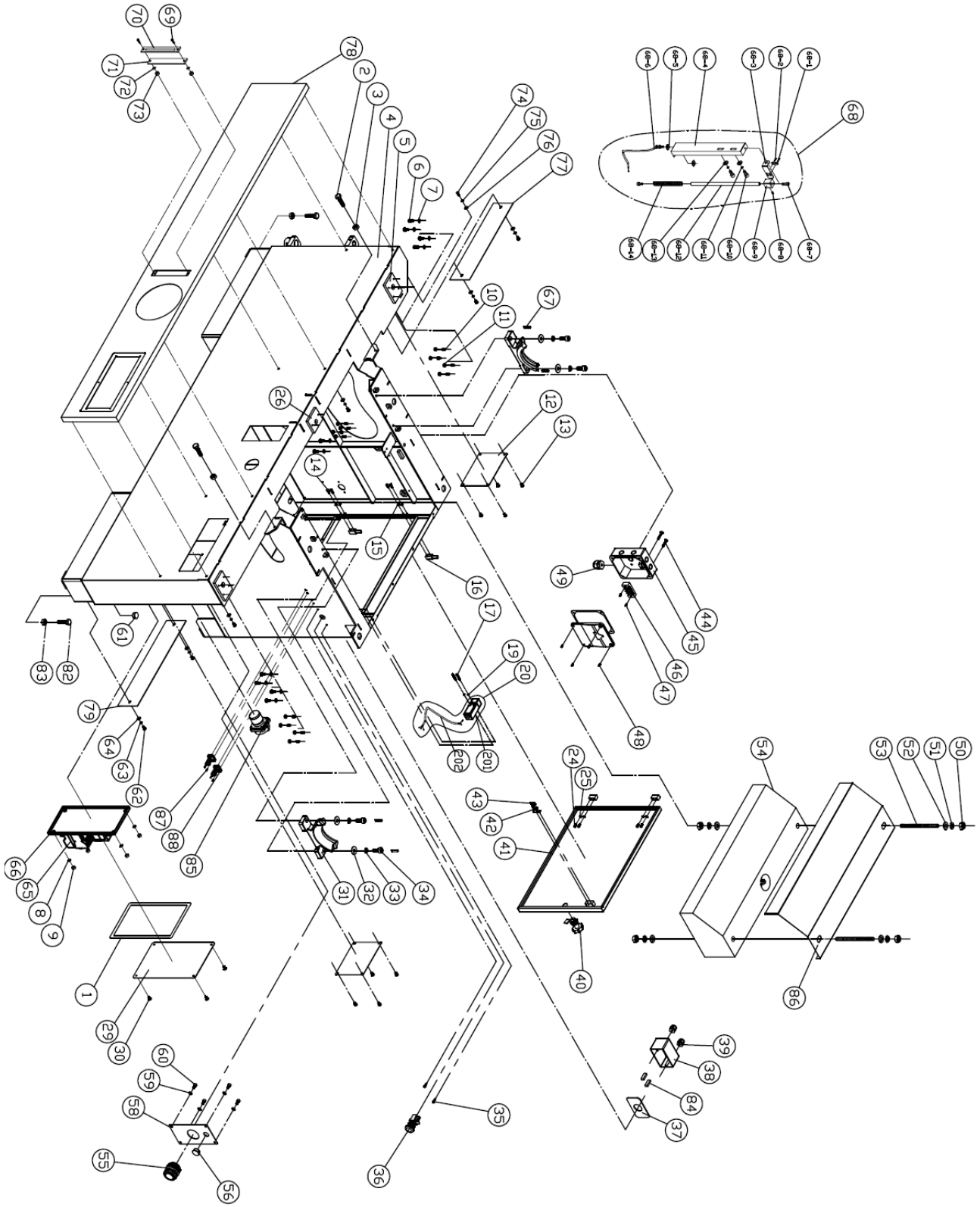

1.1 Parts list of Machine Cabinet Assembly

Index No.	Part No.	Description	Size	Qty.
1	JTSS3200X2-101	Panel Gasket	2x300x7.5 mm	4
2	TS-1491061	Hex Head Bolt	M10x40	2
3	TS-2311101	Hex. Nut	M10	2
4	JTSS3200X2-104	Machine Main Frame		1
5	JTSS3200X2-105	Table Mounting Plate		2
6	TS-1503031	Socket Head Cap Screw	M6x12	10
7	TS-2361061	Lock Washer	M6	10
8	TS-1550041	Flat Washer	M6x13	4
9	JTSS3200X2-109	Hex Flange Nut	M6	4
10	TS-1523061	Socket Set Screw	M6x20	12
11	TS-1540041	Hex Nut	M6	12
12	JTSS3200X2-112	Frame Rear Panel		2
13	TS-2246122	Socket Button Head Screw	M6x12	8
14	TS-1502031	Socket Head Cap Screw	M5x12	4
15	TS-2361051	Lock Washer	M5	4
16	JTSS3200X2-116	Door Hinge		2
17	TS-2284302	Pan Head Screw	M4x30	2
19	TS-1550021	Flat Washer	M4	2
20	JTSS-3200X2-120	Cabinet Door Limit Switch Assembly		1
20-1	JTSS-3200X2-120-1	Cabinet Door Limit Switch	AZD-S11	1
20-2	JTSS-3200X2-120-2	Door Limit switch Cord	0.75mm ² x2Cx2Y2	1
24	TS-1502011	Socket Head Cap Screw	M5x8	4
25	TS-2361051	Lock Washer	M5	4
26	JTSS3200X2-126	Table Middle Mounting Plate		1
29	JTSS3200X2-129	Electric Appliance Cover Panel		1
30	TS-2246102	Socket Button Head Screw	M6x10	4
31	JTSS3200X2-131	Blade Tilt Trunnion		2
32	TS-1550071	Flat Washer	M10	4
33	TS-2361101	Lock Washer	M10	4
34	TS-1505051	Socket Head Cap Screw	M10x35	4
35	ST050400	Tap Screw	M5x20	2
36	JTSS3200X2-136	Emergency Stop Button	R2PNR4-1B-R	1
37	JTSS3200X2-137	Gasket		1
38	JTSS3200X2-138	Switch Box		1
39	JTSS3200X2-139	Strain Relief		2
40	JTSS3200X2-140	Cabinet Door Lock		1
41	JTSS3200X2-141	Cabinet Door		1
42	TS-2361041	Lock Washer	M4	2
43	TS-2284202	Pan Head Screw	M5x8	2
44	TS-2245122	Socket Button Head Screw	M5x12	4
45	JTSS3200X2-145	Wiring Junction Box		1
46	JTSS3200X2-146	Terminal Block	PB2504 4P	1
47	TS-2284202	Pan Head Screw	M5x8	2
48	TS-2245122	Socket Button Head Screw	M5x12	4
49	JTSS3200X2-149	Strain Relief	PG20	2
50	TS-1540081	Hex Nut	M12	4

Index No.	Part No.	Description	Size	Qty.
51	TS-2361121	Lock Washer	M12	4
52	TS-2360121	Flat Washer	M12	4
53	JTSS3200X2-153	All Thread Stud	M12-1.75x185	2
54	JTSS3200X2-154	Concrete Block		1
55	JTSS3200X2-155	Strain Relief	MG20X1.65	1
56	JTSS3200X2-156	Hole Plugs	HP-22	1
58	JTSS3200X2-158	Cord Fixing Plate		1
59	TS-2361061	Lock Washer	M6	4
60	TS-1503031	Socket Head Cap Screw	M6x12	4
61	JTSS3200X2-156	Hole Plugs	HP-22	1
62	TS-2246122	Socket Button Head Screw	M6x12	4
63	TS-2361061	Lock Washer	M6	4
64	TS-1550041	Flat Washer	M6	4
65	JTSS3200X2-165	Electric Appliance Panel Assembly		1
66	JTSS3200X2-166	Electric Appliance Back Panel		1
67	JTSS3200X2-167	Roll Pin	Ø6x25	4
68	JTSS3200x2-168	Steel Wire Assembly		1
68-1	TS-1550031	Flat Washer	M5	2
68-2	TS-1533032	Pan Head Screw	M5x10	2
68-3	JTSS3200X2-168-3	Pointer		1
68-4	JTSS3200X2-168-4	Tilt Scale Bracket		1
68-5	TS-1550041	Flat Washer	M6	2
68-6	JTSS3200X2-168-6	Steel Wire		1
68-7	TS-1502021	Socket Head Cap Screw	M5x10	2
68-8	TS-1522031	Socket Set Screw	M5x10	1
68-9	JTSS3200X2-168-9	Pointer Bracket		1
68-10	TS-1503031	Socket Head Cap Screw	M6x12	2
68-11	TS-2361061	Lock Washer	M6	2
68-12	JTSS3200X2-168-12	Shaft		1
68-13	TS-1550041	Flat Washer	M6	2
68-14	JTSS3200X2-168-14	Compression Spring		1
69	TS-2284202	Pan Head Screw	M4x20	2
70	JTSS3200X2-170	Scale Plate Cover		1
71	JTSS3200X2-171	Tilt Scale		1
72	TS-1550021	Flat Washer	M4	2
73	TS-1540021	Hex. Nut	M4	2
74	TS-1503031	Socket Head Cap Screw	M6x12	8
75	TS-2361061	Lock Washer	M6	8
76	TS-1550041	Flat Washer	M6	8
77	JTSS3200X2-177	Left Bottom Cabinet Panel		1
78	JTSS3200X2-178	Cabinet Front Cover		1
79	JTSS3200X2-179	Right Bottom Cabinet Panel		1
82	TS-2213501	Hex. Head Bolt	M16x50	4
83	TS-154010	Hex. Nut	M16	4
84	JTSS3200X2-184	Cord Connector	224-201	2
85	JTSS3200X2-185	Main Power Switch	ZH-HD-2	1
86	JTSS3200X2-186	Concrete Block Cover Plate		1
87	ST049300	Tappin Screw		4
88	JTSS3200X2-188	Hanger		2

2.0 Exploded Drawing of Main Task Table & Extension Table Assembly

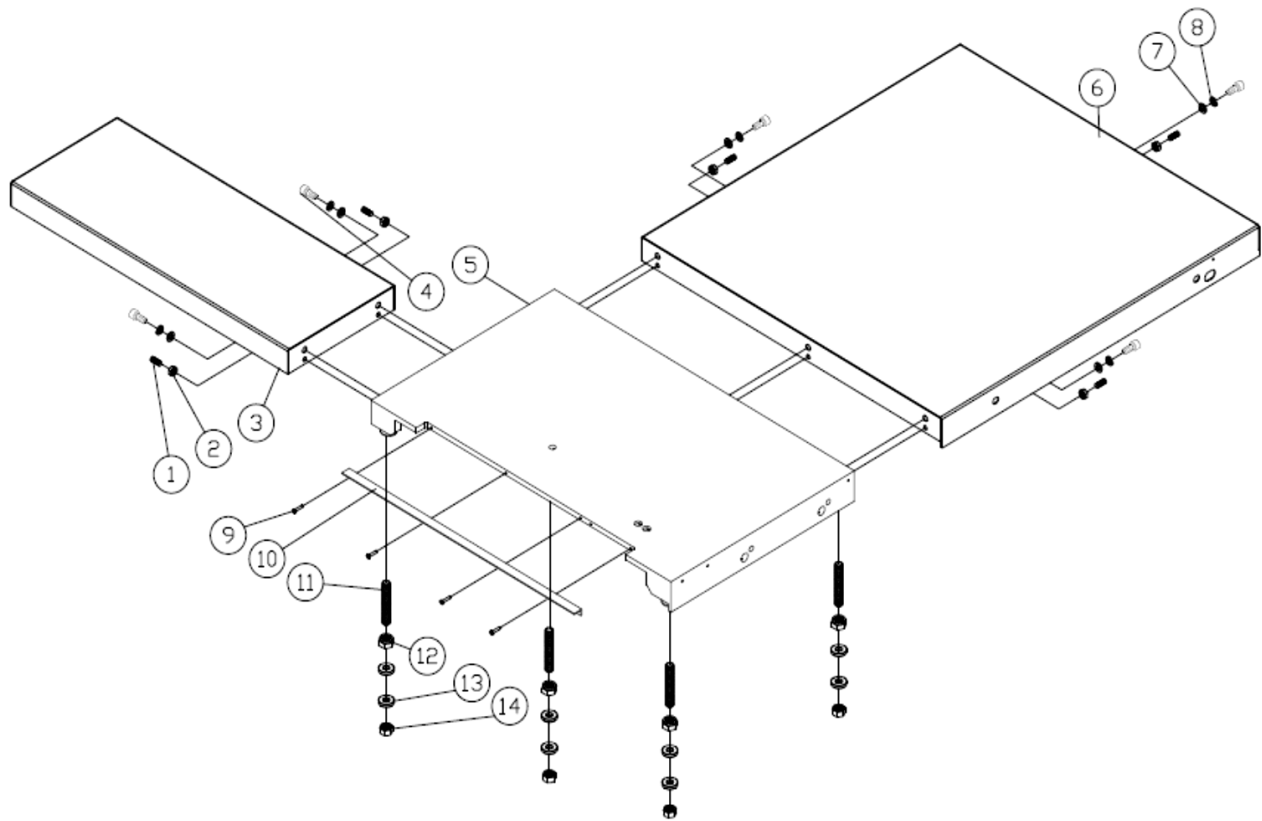

2.1 Parts list of Main Task Table & Extension Table Assembly

Index No.	Part No.	Description	Size	Qty.
1	TS-1525041	Socket Set Screw	M10x20	5
2	TS-2311101	Hex. Nut	M10	5
3	JTSS3200X2-203	Left Extension Wing		1
4	TS-1505031	Socket Head Cap Screw	M10x25	5
5	JTSS3200X2-205	Main Saw Table		1
6	JTSS3200X2-206	Rear Extension Wing		1
7	TS-1550071	Flat Washer	M10	5
8	TS-2361101	Lock Washer	M10	5
9	TS-2246122	Socket Button Head Screw	M6x12	4
10	JTSS3200X2-210	Table Insert		1
11	208436	Socket Set Screw	M16*100	4
12	TS-2342161	Hex. Nut Nylon Lock	M16	4
13	JTSS3200X2-213	Table Mount Spacer	16 mm	8
14	TS-2311161	Hex. Nut	M16	4

3.0 Exploded Drawing of Control Panel Assembly

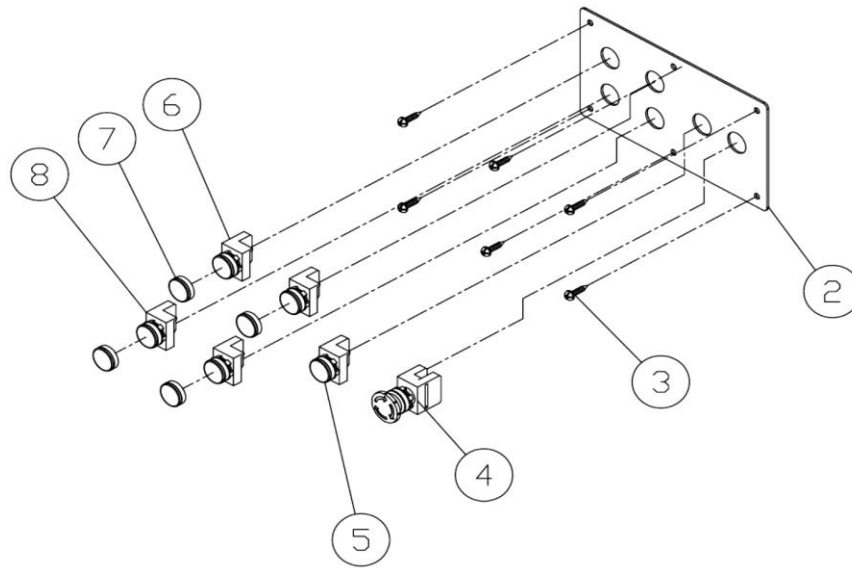

3.1 Parts list of Control Panel Assembly

Index No.	Part No.	Description	Size	Qty.
2	JTSS3200X2-302	Panel		1
3	TS-2245102	Socket Button Head Screw	M5x10	6
4	JTSS3200X2-304	Emergency Stop Button		1
5	JTSS3200X2-305	Pilot Lamp	YK.24V φ22 (W)	1
6	JTSS3200X2-306	Switch Button-ON	R2 PNF-1A-G	2
7	JTSS3200X2-307	Button Dust Cover	R2 PRCF	4
8	JTSS3200X2-308	Switch Button-OFF	R2 PNF-1B-R	2

4.0 Exploded Drawing of Main Blade Trunnion

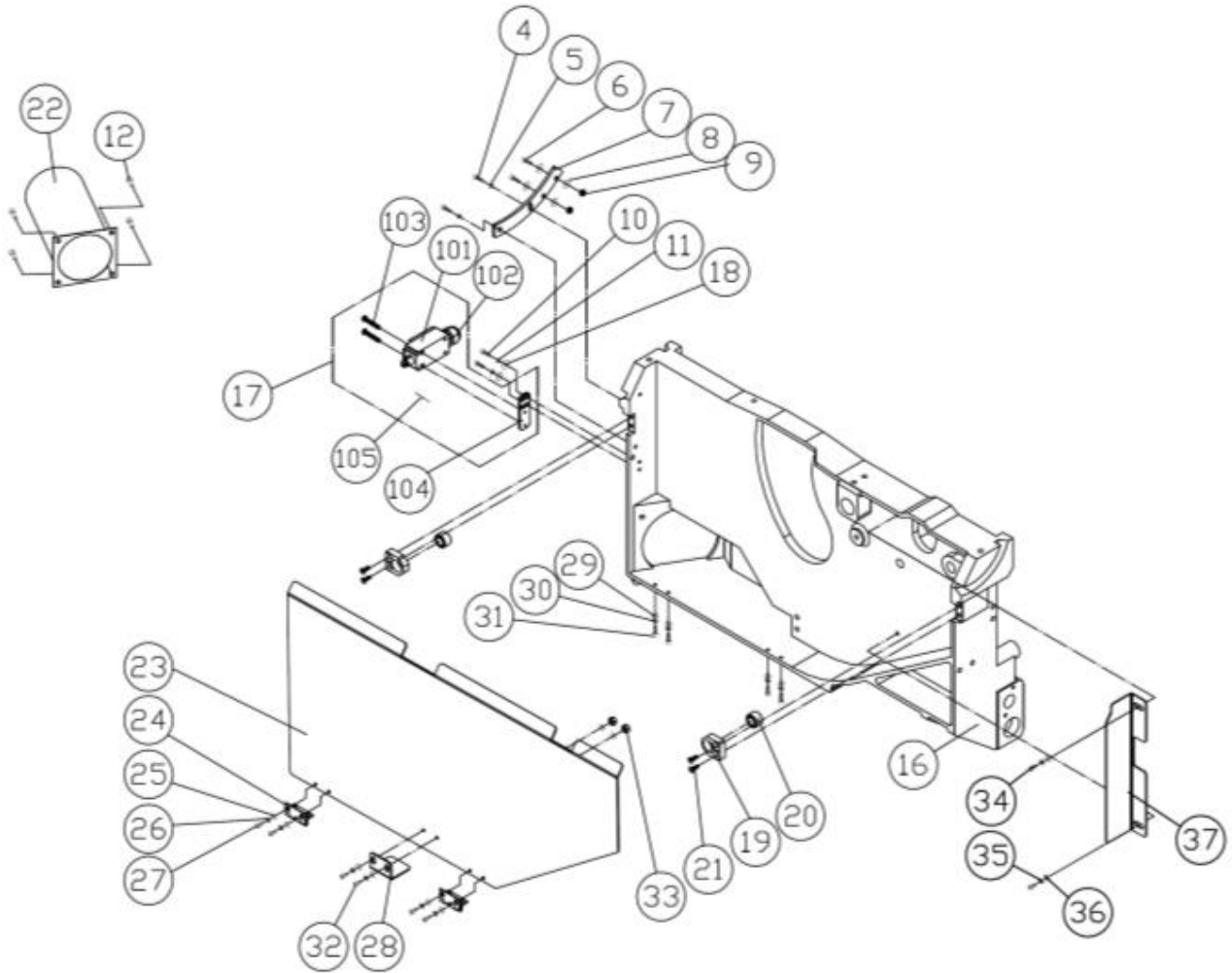

4.1 Parts list of Main Blade Trunnion

Index No.	Part No.	Description	Size	Qty.
4	TS-1503031	Socket Head Cap Screw	M6x12	2
5	TS-2361101	Lock Washer	M10	2
6	TS-1502041	Socket Head Cap Screw	M5x16	2
7	JTSS3200X2-407	Angle Plate		1
8	TS-1550031	Flat Washer	M5x10	4
9	TS-1541011	Hex. Nut Nylon Lock	M5	2
10	TS-1502031	Socket Head Cap Screw	M5x12	2
11	TS-2361051	Lock Washer	M5	2
12	TS-1481031	Hex. Cap Screw	M5x12	2
16	JTSS3200X2-416	Elevation Trunnion		1
17	JTSS3200X2-417	Blade Cover Safety Switch Assembly		1
101	JTSS3200X2-417-101	Safety Limit Switch		1
102	JTSS3200X2-417-102	Strain Relief	PG-11	1
103	SP040700	Pan Head Screw	M4x35	2
104	JTSS3200X2-417-104	Safety Limit Switch Bracket		1
105	JTSS3200X2-417-105	Limit Switch Cord	0.75mm ² x2Cx2M	1
18	TS-1550031	Flat Washer	M5x10	2
19	JTSS3200X2-419	Magnet Holder		2
20	TS-2311161	Blade Cover Magnet		2
21	SM060400	Sunk Head Socket Screw	M6x20	4
22	JTSS3200X2-422	Dust Port		1
23	JTSS3200X2-423	Blade Cover		4
24	JTSS3200X2-424	Blade Cover Hinge		2
25	TS-1550031	Flat Washer	M5x10	8
26	TS-2361051	Lock Washer	M5	6
27	TS-1502011	Socket Head Cap Screw	M5x8	4
28	JTSS3200X2-428	Blade Cover Hinge Bracket		1
29	TS-1550031	Flat Washer	M5x10	4
30	TS-2361051	Lock washer	M5	4
31	TS-1502021	Socket Head Cap Screw	M5x10	4
32	TS-1502041	Socket Head Cap Screw	M5x16	2
33	TS-1540031	Nex. Nut	M5	2
34	TS-1503021	Socket Head Cap Screw	M6x10	2
35	TS-2361061	Lock Washer	M6	2
36	TS-1550041	Flat Washer	M6	2
37	JTSS3200X2-437	Blade Partition Plate		1

5.0 Exploded Drawing of Main Blade Motor & Drive Assembly

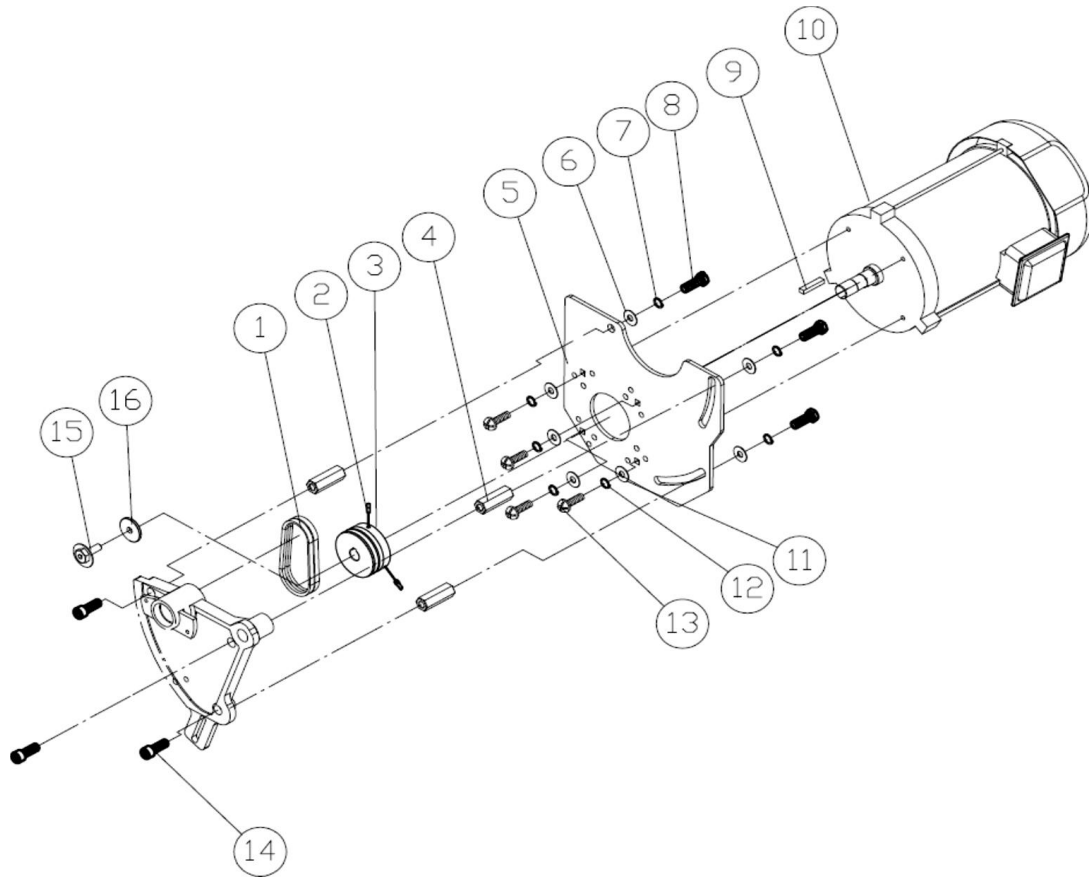

5.1 Parts list of Main Blade Motor & Driving Assembly

Index No.	Part No.	Description	Size	Qty.
1	JTSS3200X2-501	V-Belt	3VX-265	1
2	TS-1524021	Socket Set Screw	M8x10	6
3	JTSS3200X2-503	Main Blade Motor Pulley		1
4	JTSS3200X2-504	Spacer	M10x25	5
5	JTSS3200X2-505	Main Blade Mounting Plate		1
6	WF132225	Motor Mount Flat Washer	M13	3
7	TS-2361121	Lock Washer	M12	3
8	TS-1492031	Hex. Cap Screw	M12x35	3
9	JTSS3200X2-509	Key	8x7x45	1
10	JTSS3200X2-510	Main Blade Motor	3.75KW 3PH 50Hz 400V..	1
	994742	Motor brake for JTSS-3200X2	YZG2-1.2	1
11	TS-1550061	Flat Washer	M8	4
12	TS-2361081	Lock Washer	M8	4
13	TS-2208201	Hex. Cap Screw	M8x20	4
14	TS-1506031	Socket Head Cap Screw	M12x30	3
15	TS-1505021	Socket Head Cap Screw	M10x20 (Left Helix) ..	1
16	TS-1550071	Flat Washer	M10	1

6.0 Exploded Drawing of Main Blade Arbor Mechanism

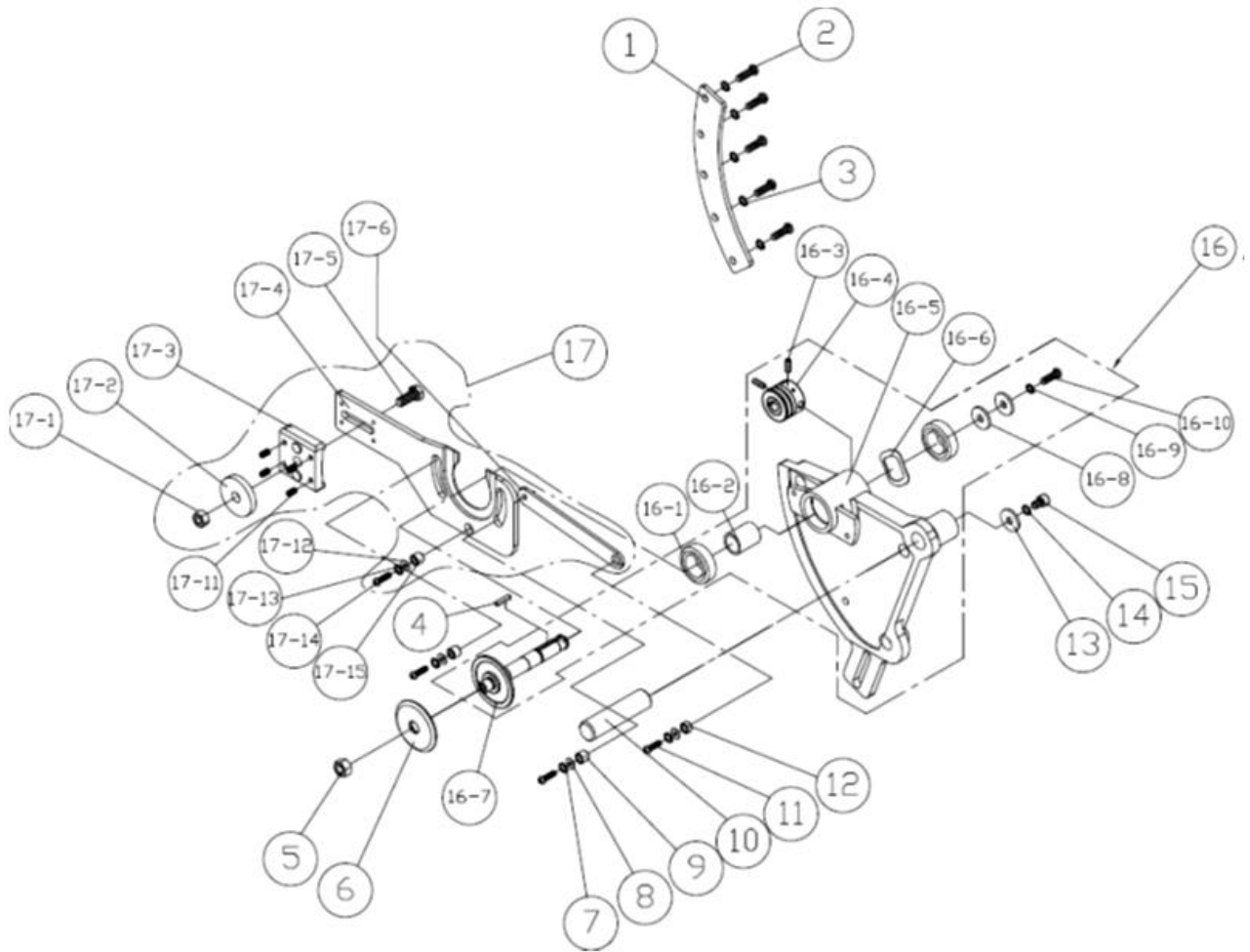

6.1 Parts list of Main Blade Arbor Mechanism

Index No.	Part No.	Description	Size	Qty.
1	JTSS3200X2-601	Gip Plate		1
2	TS-2249252	Socket Button Head Screw	M10x25	5
3	TS-2361101	Lock Washer	M10	5
4	JTSS3200X2-604	Double Round Flat Key	5x5x20	1
5	201822	Hex. Nut	M16x2 (left helix)	1
6	JTSS3200X2-606	Main Blade Arbor Flange	25.4 mm	1
7	TS-2361081	Lock Washer	M8	3
8	TS-1550061	Flat Washer	M8	3
9	JTSS3200X2-609	Bushing		3
10	JTSS3200X2-610	Arbor Housing Pivot Shaft		1
11	TS-2248202	Socket Button Head Screw	M8x20	3
12	JTSS3200X2-612	Bushing		1
13	TS-1550061	Flat Washer	M8	1
14	TS-2361081	Lock Washer	M8	1
15	TS-1490031	Hex. Cap Screw	M8x20	1
16	JTSS3200X2-616	Arbor Housing Assembly		1
16-1	BB-6206VV	Ball Bearing	6206 LLB	2
16-2	JTSS3200X2-616-2	Bearing Spacer		1
16-3	TS-1522031	Socket Set Screw	M5x10	3
16-4	JTSS3200X2-616-4	Main Blade Arbor Pulley		1
16-5	JTSS3200X2-616-5	Main Blade Arbor Housing		1
16-6	JTSS3200X2-616-6	Wave Washer	Ø47×Ø60	2
16-7	JTSS3200X2-616-7	Main Blade Arbor	Ø30	1
16-8	TS-1550061	Flat Washer	M8	2
16-9	TS-2361081	Lock Washer	M8	1
16-10	TS-2248202	Socket Button Head Screw	M8x20	1
17	JTSS3200X2-617	Riving Knife Bracket Assembly		1
17-1	TS-2311101	Hex. Nut	M10	1
17-2	TS-1550071	Flat Washer	M10	1
17-3	JTSS3200X2-617-3	Front Riving Knife Bracket		1
17-4	JTSS3200X2-617-4	Riving Knife Bracket		1
17-5	SC100700	Carriage Bolt	M10x35	1
17-6	JTSS3200X2-617-6	Pivot Link Plate		1
17-11	TS-1522031	Socket Set Screw	M5x10	4
17-12	TS-1550061	Flat Washer	M8	1
17-13	TS-2361081	Lock Washer	M8	1
17-14	TS-2248202	Socket Button Head Screw	M8x20	1
17-15	JTSS3200X2-612	Bushing		1

7.0 Exploded Drawing of Tilt Hand-wheels Mechanism

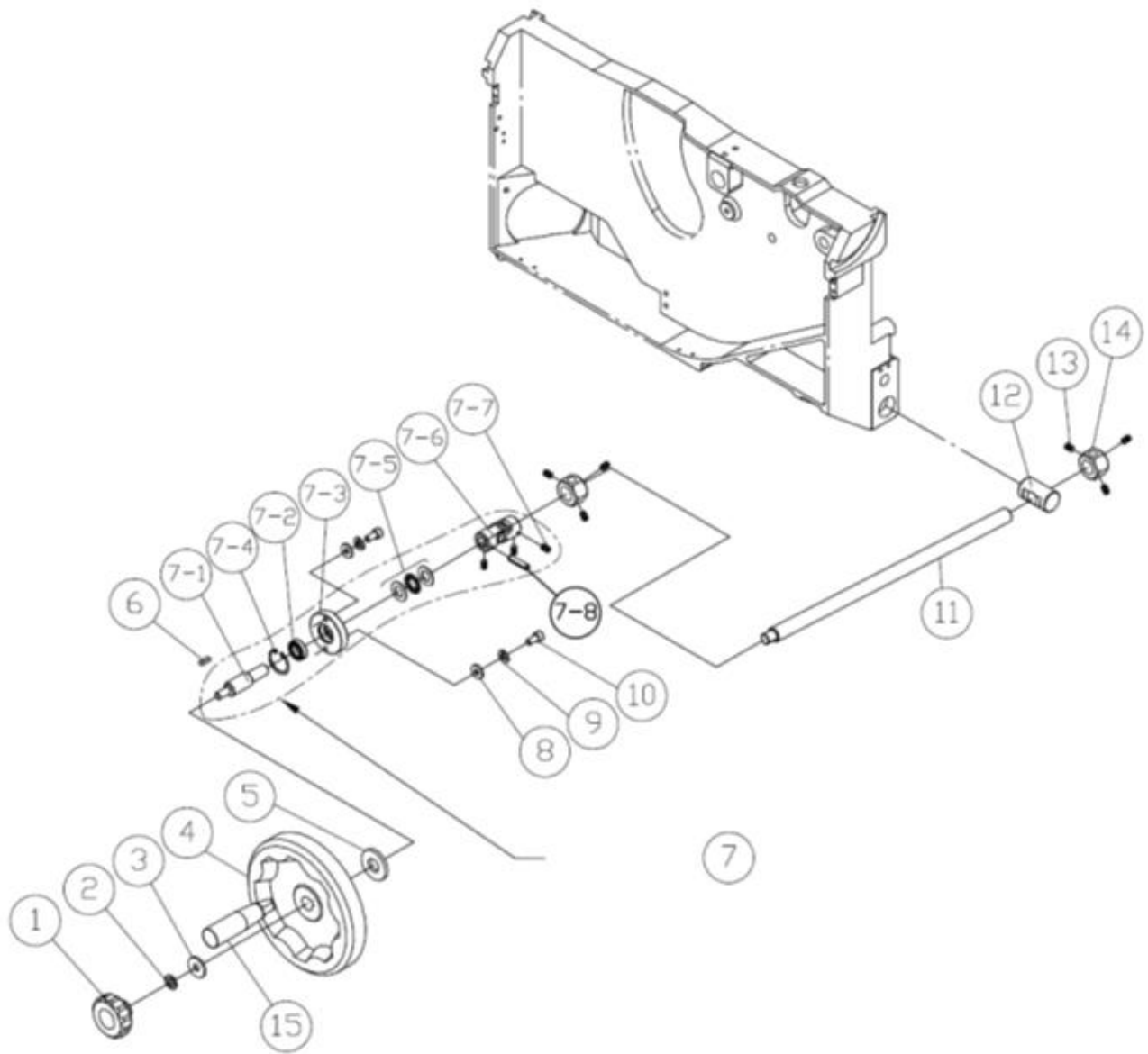

7.1 Parts list of Tilt & Elevation Hand-wheel Mechanism

Index No.	Part No.	Description	Size	Qty.
1	JTSS3200X2-701	Lock Knob	M10	1
2	TS-1550071	Flat Washer	M10	1
3	JTSS3200X2-703	Plastic Washer	M10×Ø27	1
4	JTSS3200X2-704	Tilt Hand Wheel		1
5	JTSS3200X2-705	Bearing Washer	T8	1
6	JTSS3200X2-706	Key	7x7x20	1
7	JTSS3200X2-707	Hand Wheel Shaft Assembly		1
7-1	JTSS3200X2-707-1	Hand Wheel Shaft		1
7-2	JTSS3200X2-707-2	Ball Bearing	6902ZZ	1
7-3	JTSS3200X2-707-3	Bearing Seat		1
7-4	JTSS3200X2-707-4	Ext. Retaining Ring	28 mm	1
7-5	JTSS3200X2-707-5	Trust Bearing	NTB1528 AS	1
7-6	JTSS3200X2-707-6	Universal Joint	Ø 14	1
7-7	TS-1523011	Socket Set Screw	M6×6	1
7-8	JTSS3200X2-707-8	Spring Pin	Ø6×Ø26	1
8	TS-2361081	Lock Washer	M8×Ø18	2
9	TS-2361081	Lock Washer	M8	2
10	TS-1504041	Socket Head Cap Screw	M8x20	2
11	JTSS3200X2-711	Tilt Lead Screw		1
12	JTSS3200X2-712	Trunnion with Lead Screw Connector		1
13	TS-1523011	Socket Set Screw	M6x6	6
14	JTSS3200X2-714	Tilt Lead Screw Nut		2
15	JTSS3200X2-715	Tilt Hand Wheel Bar		1

8.0 Exploded Drawing of Elevation Hand-wheel Mechanism

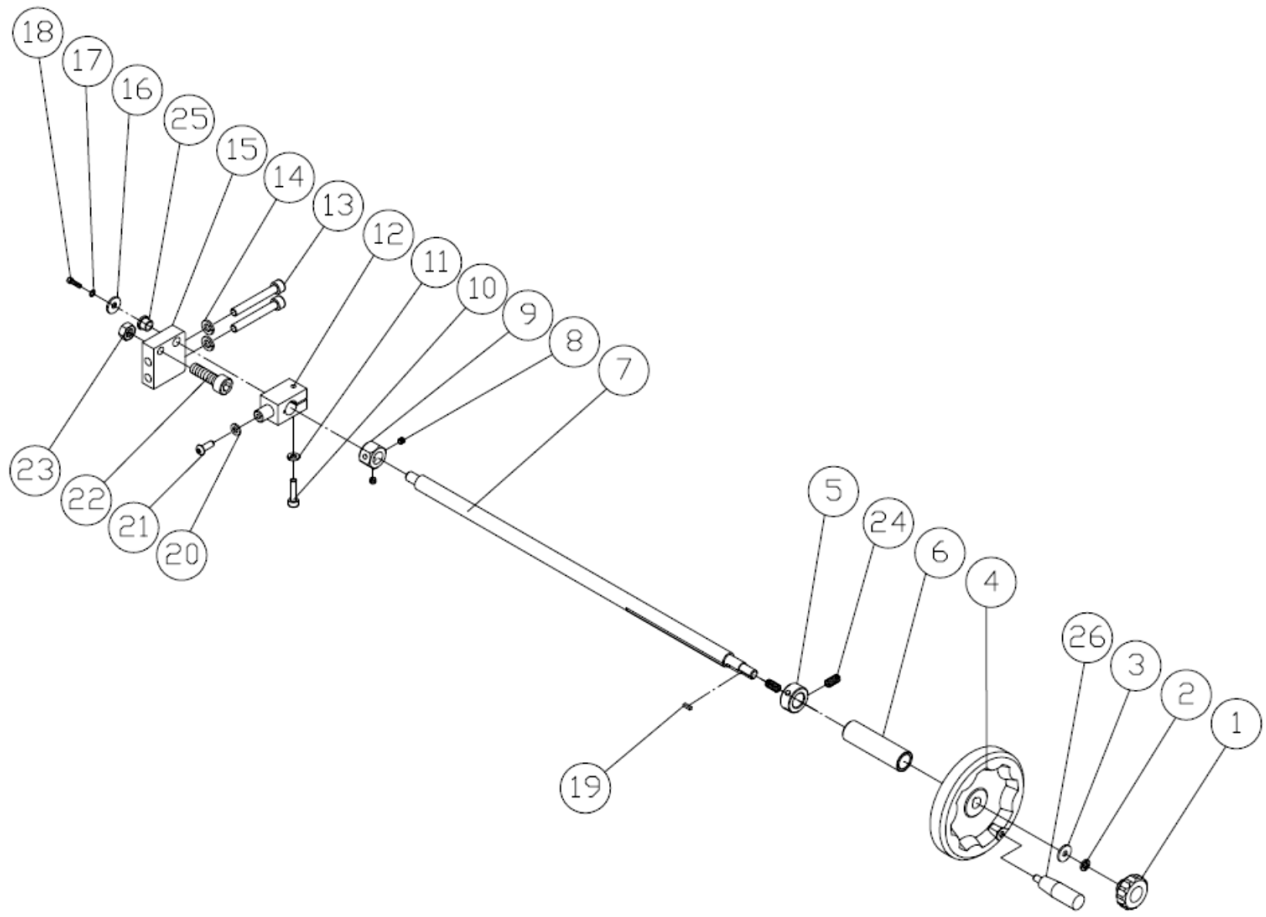

8.1 Parts List of Elevation Hand-wheel Mechanism

Index No.	Part No.	Description	Size	Qty.
1	JTSS3200X2-701	Lock Knob	M10	1
2	TS-1550071	Flat Washer	M10	1
3	JTSS3200X2-803	Plastic Washer	M10×Ø30	1
4	JTSS3200X2-804	Elevation Hand Wheel Assembly		1
5	JTSS3200X2-805	Lock Collar		1
6	JTSS3200X2-806	Lead Screw Sleeve		1
7	JTSS3200X2-807	Elevation Lead Screw		1
8	TS-1523011	Socket Set Screw	M6x6	3
9	JTSS3200X2-714	Elevation Lead Screw Nut		1
10	TS-1503071	Socket Head Cap Screw	M6x30	1
11	TS-2361061	Lock Washer	M6	2
12	JTSS3200X2-812	Elevation Lead Screw Clamp		1
13	TS-1504101	Socket Head Cap Screw	M8x50	2
14	TS-2361081	Lock Washer	M8	2
15	JTSS3200X2-815	Lead Screw Bracket		1
16	TS-1550041	Flat Washer	M6	1
17	TS-2361061	Lock Washer	M6	1
18	TS-1503031	Socket Head Cap Screw	M6x12	1
19	JTSS3200X2-819	Single Round Key	5x5x20	1
20	TS-1550041	Flat Washer	M6	1
21	TS-1503021	Socket Head Cap Screw	M6x10	1
22	TS-1505051	Socket Head Cap Screw	M10×35	1
23	TS-1540071	Hex. Nut	M10	1
24	TS-1523021	Socket Set Screw	M6x8	2
25	JTSS3200X2-825	Self-lubricating Bearing		1
26	JTSS3200X2-826	Tilt Hand Wheel Bar		1

9.0 Exploded Drawing of Scoring Blade Arbor & Adjustment Assembly

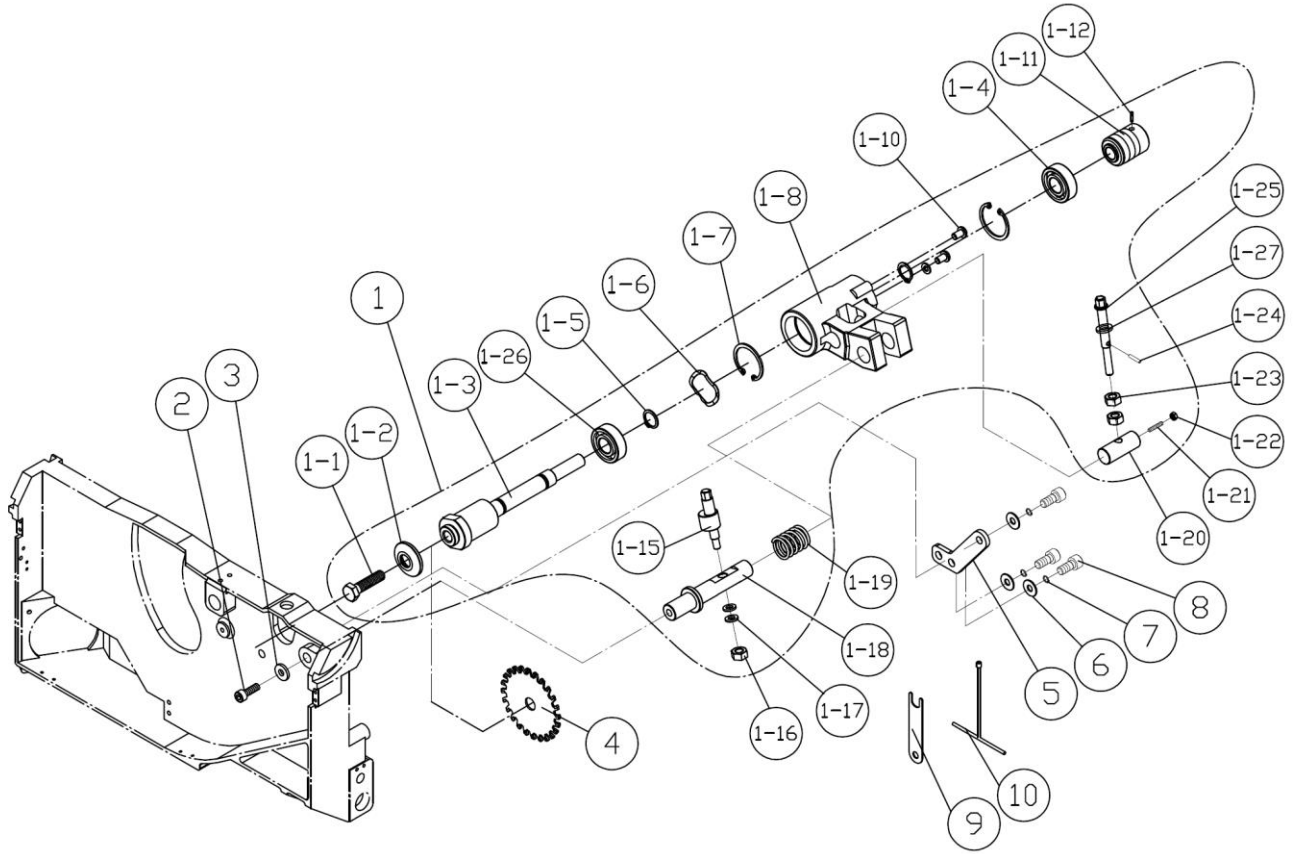

9.1 Parts List of Scoring Blade Arbor & Adjustment Assembly

Index No.	Part No.	Description	Size	Qty.
1	JTSS3200X2-901	Scoring Blade Arbor Assembly		1
1-1	SH120440	Hex. Cap Screw	M12x20	1
1-2	JTSS3200X2-901-2	Scoring Blade Arbor Flange		1
1-3	JTSS3200X2-901-3	Scoring Blade Arbor		1
1-4	BB-6202VV	Ball Bearing	6202LLB	1
1-5	JTS700-RS150000	Int. Retaining Ring	15 mm	2
1-6	JTSS3200X2-901-6	Wave Washer	Ø26xØ34 thk.0.3	1
1-7	JTSS3200X2-901-7	Int. Retaining Ring	35 mm	2
1-8	JTSS3200X2-901-8	Scoring Blade Arbor Housing		1
1-10	TS-1482021	Hex. Cap Screw	M6x12	2
1-11	JTSS3200X2-901-11	Scoring Blade Arbor Pulley		1
1-12	TS-1523011	Socket Set Screw	M6x6	3
1-15	JTSS3200X2-901-15	Eccentric Shaft		1
1-16	TS-1541021	Hex. Nut Nylon Lock	M6	1
1-17	JTSS3200X2-901-17	Belleville Disc Spring	Ø15xØ6.2x0.5 thk.	2
1-18	JTSS3200X2-901-18	Horizontal Adjustment Shaft		1
1-19	JTSS3200X2-901-19	Compression Spring		1
1-20	JTSS3200X2-901-20	Vertical Adjustment Shaft		1
1-21	TS-1523071	Socket Set Screw	M6x25	1
1-22	TS-1540041	Hex. Nut	M6	1
1-23	TS-1540061	Hex. Nut	M8	2
1-24	JTSS3200X2-901-24	Roll Pin	Ø2.5x12	1
1-25	JTSS3200X2-901-25	Vertical Adjustment Bolt		1
1-26	BB-6003VV	Ball Bearing	6003LLB	1
1-27	TS-1550061	Flat Washer	M8	1
2	TS-1504041	Socket Head Cap Screw	M8x20	1
3	WF083030	Flat Washer	M8x Ø30	1
4	JTSS3200X2-904	Scoring Saw Blade	Ø20	1
5	JTSS3200X2-905	Pivot Arm		1
6	TS-1550041	Flat Washer	M6	3
7	TS-2361061	Lock Washer	M6	3
8	TS-1503041	Socket Head Cap Screw	M6x16	3
9	JTSS3200X2-909	Wrench		1
10	JTSS3200X2-910	T Screw Driver	8 mm	1

10.0 Exploded Drawing of Scoring Blade Motor & Drive Assembly

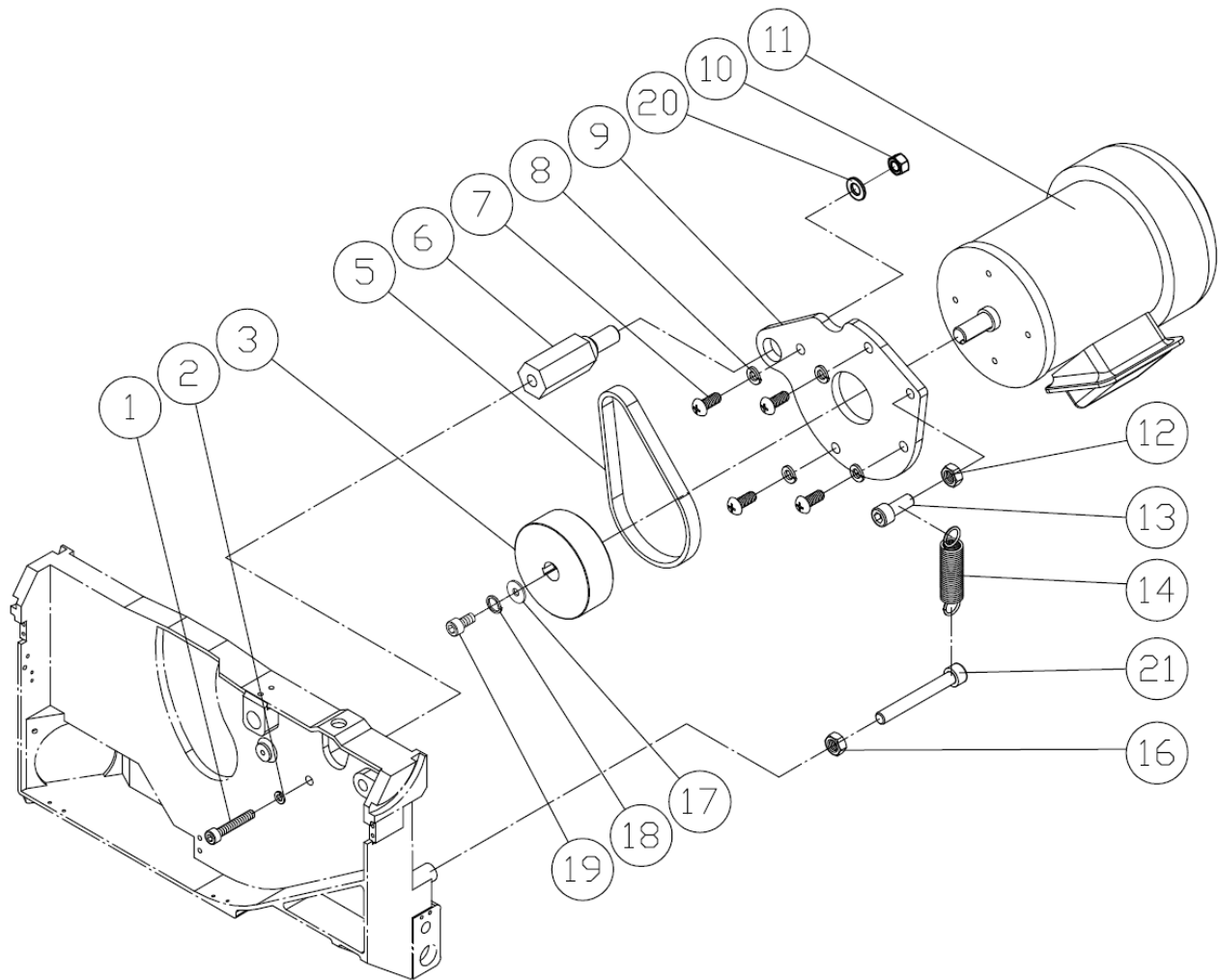

10.1 Parts List of Scoring Blade Motor & Drive Assembly

Index No.	Part No.	Description	Size	Qty.
1	TS-223A911	Socket Head Cap Screw	M12x100	1
2	TS-2361121	Lock Washer		1
3	JTSS3200X2-1003	Scoring Blade Motor Pulley		1
5	JTSS3200X2-1005	Belt	18WX380L	1
6	JTSS3200X2-1006	Pivot Shaft		1
7	TS-2248202	Socket Button Head Screw	M8x20	4
8	TS-2361081	Lock Washer	M8	4
9	JTSS3200X2-1009	Scoring Blade Motor Mounting Plate		1
10	TS-2342141	Hex. Nut Nylon Lock	M14	1
11	JTSS3200X2-1011	Scoring Blade Motor	0.55KW 3PH 50HZ 400V	1
12	TS-2311101	Hex. Nut	M10	1
13	TS-1505031	Socket Head Cap Screw	M10x25	1
14	JTSS3200X2-1014	Tension Spring		1
16	TS-2311101	Hex. Nut	M10	1
17	WF063030	Flat Washer	M6x30	1
18	TS-2361061	Lock Washer	M6	1
19	TS-1503041	Socket Head Cap Screw	M6x16	1
20	TS-155009	Flat Washer	M14	1
21	SR101700	Socket Head Cap Screw	M10x85	1

11.0 Exploded Drawing of Swing Arm Assembly

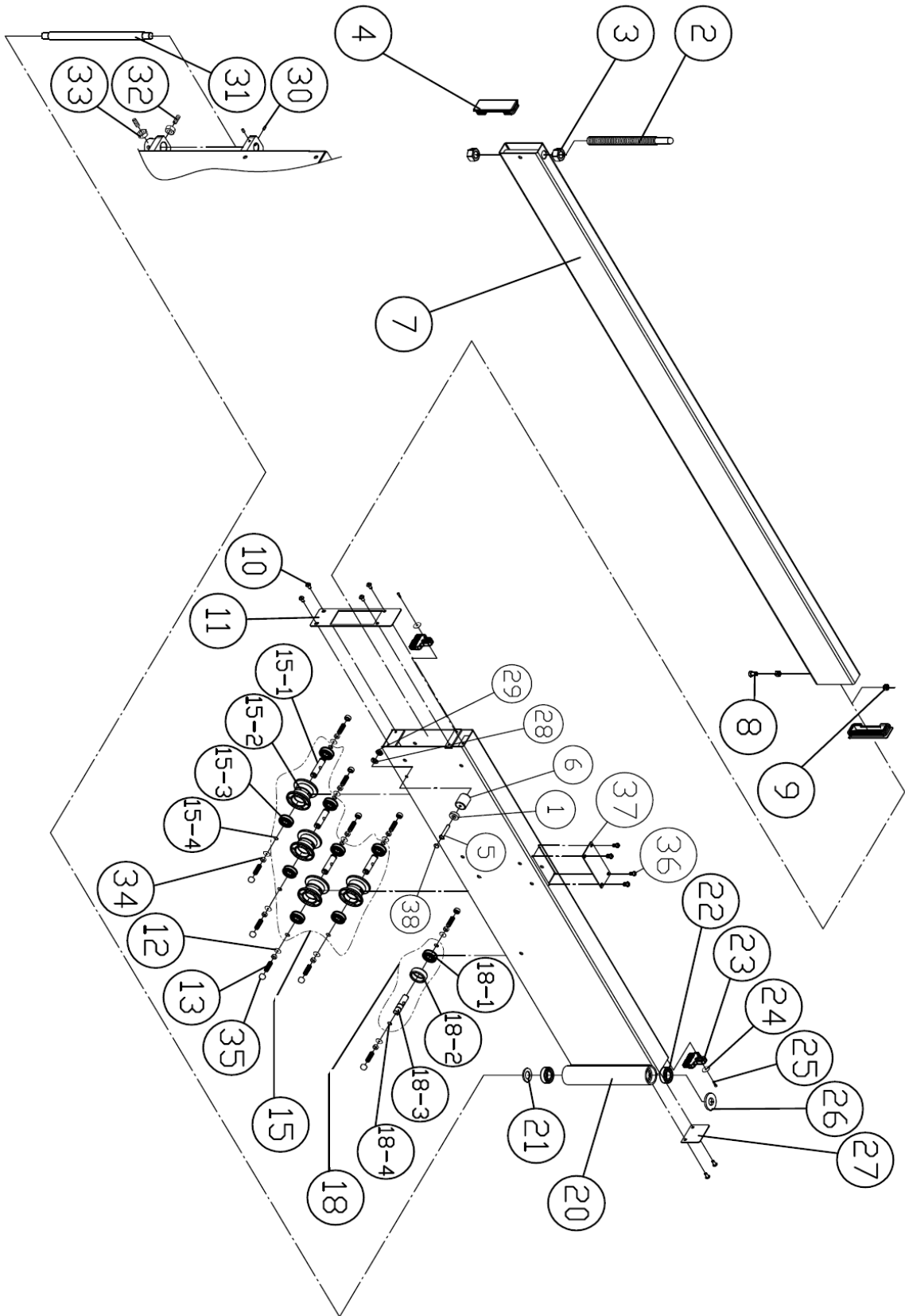

11.1 Parts List of Swing Arm Assembly

Index No.	Part No.	Description	Size	Qty.
1	JTSS3200X2-1101	Magnet		1
2	JTSS3200X2-1102	Crosscut Frame Rotary Pivot		1
3	NH203000	Hex. Nut	M20x2.5P	1
4	JTSS3200X2-1104	Sliding Tube End Plug	40x120 mm	2
5	SI051100	Counter Sunk Screw	M5x55	1
6	JTSS3200X2-1106	Magnetic Bracket	22 mm	1
7	JTSS3200X2-1107	Sliding Tube	3200 mm	1
8	TS-1504041	Socket Head Cap Screw	M8x20	1
9	TS-1540061	Hex. Nut	M8	2
10	TS-2246102	Socket Button Head Screw	M6x10	6
11	JTSS3200X2-1111	Swing Arm Cover Plate		1
12	TS-1550061	Flat Washer	M8	8
13	TS-1524061	Socket Set Screw	M8x25	8
15	JTSS3200X2-1115	Swing Arm Roller Assembly		3
15-1	JTSS3200X2-1115-1	Swing Arm Roller Axle		1
15-2	JTSS3200X2-1115-2	Swing Arm Roller		1
15-3	BB-6202ZZ	Ball Bearing	6202ZZ	2
15-4	JTSS3200X2-1115-4	Ext. Retaining Ring	15 mm	2
18	JTSS3200X2-1118	Bearing Shaft Assembly		1
18-1	BB-6202ZZ	Ball Bearing	6202ZZ	1
18-2	JTSS3200X2-1118-2	Bearing Spacer		1
18-3	JTSS3200X2-1118-3	Bearing Shaft		1
18-4	JTS700-RS150000	Ext. Retaining Ring	15 mm	2
20	JTSS3200X2-1120	Swing Arm		1
21	TS-1550111	Flat Washer	M20	1
22	BB-6004ZZ	Ball Bearing	6004ZZ	1
23	JTSS3200X2-1123	Brush		2
24	TS-1550041	Flat Washer	M6	2
25	TS-1503051	Socket Head Cap Screw	M6x20	2
26	TS-1550111	Flat Washer	M20	1
27	JTSS3200X2-1127	Brush Cover		1
28	TS-2361081	Lock Washer	M8	1
29	203239	Hex. Nut	M8x1.25P	1
30	TS-1525011	Socket Set Screw	M10x10	3
31	JTSS3200X2-1131	Swing Arm Pivot Shaft		1
32	TS-1525041	Socket Set Screw	M10x20	4
33	TS-1540071	Hex. Nut	M10	4
34	TS-1540061	Hex. Nut	M8	10
35	JTSS3200X2-1135	Cover Nut	13 mm	10
36	SJ059200	Socket Button Head Screw	M5x8	4
37	JTSS3200X2-1137	Awing Arm Top Plate		1
38	JTSS3200X2-1138	Caution		1

12.0 Exploded Drawing of Crosscut Table Assembly

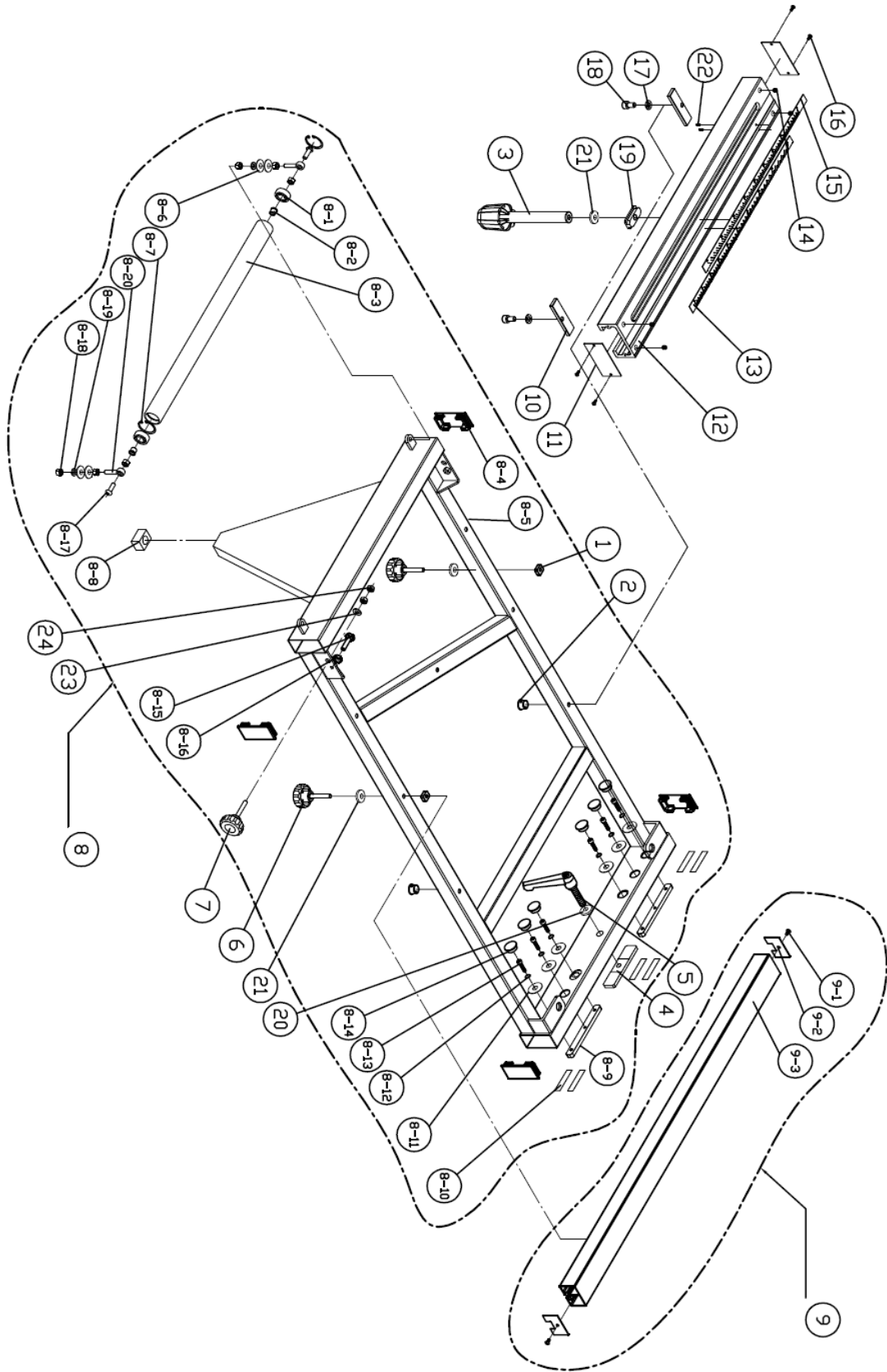

12. 1 Parts List of Crosscut Table Assembly

Index No.	Part No.	Description	Size	Qty.
1	JTSS3200X2-1201	Nut Block	M8x1.25P	2
2	JTSS3200X2-1202	Plastic Plug	HP-16	2
3	JTSS3200X2-1203	Handle		1
4	JTSS3200X2-1204	T Lock Bar		1
5	JTS700-808	L Lock Handle	M12x57Lx1.75P	1
6	JTS700-809	Knob Screw	M8x50L	2
7	JTS700-809	Knob Screw	M8x50L	1
8	JTSS3200X2-1208	Crosscut Table Frame Assembly		1
8-1	BB-6201ZZ	Ball Bearing	6201ZZ	2
8-2	JTSS3200X2-1208-2	Spacer		2
8-3	JTSS3200X2-1208-3	Roller		1
8-4	JTS700-814	Cross Table Frame End Plug	40x80 mm	4
8-5	JTSS3200X2-1208-5	Cross Table Frame		1
8-6	TS-1550061	Flat Washer	M8	4
8-7	JTSS3200X2-1208-7	Int. Retaining Ring	32 mm	2
8-8	JTSS3200X2-1208-8	Pivot Block		1
8-9	JTS700-803	Slide T-Bar		2
8-10	JTSS3200X2-1208-10	Cushion	55 mm	6
8-11	TS-1550041	Flat Washer	M6	6
8-12	TS-2361061	Lock Washer	M6	6
8-13	TS-2246162	Socket Button Head Screw	M6x16	6
8-14	JTS700-813	Round Plug		6
8-15	TS-1490051	Hex. Cap Screw	M8x30	2
8-16	TS-1540061	Hex. Nut	M8	2
8-17	TS-2248252	Socket Button Head Screw	M8x25	2
8-18	TS-1540061	Hex. Nut	M8	6
8-19	TS-2361081	Lock Washer	M8	2
8-20	JTSS3200X2-1208-20	Roller Eye Bolt	M8x40	2
9	JTSS3200X2-1209	Crosscut Table Brace Assembly		1
9-1	ST040200	Tap Screw	#8x3/8"	2
9-2	JTSS3200X2-1209-2	Crosscut Table Brace End Cover		2
9-3	JTSS3200X2-1209-3	Crosscut Table Brace		1
10	JTSS3200X2-1210	Fix Block		2
11	JTSS3200X2-1211	End Cover Plate		2
12	JTSS3200X2-1212	Aluminum Extrusion Square Tube		1
13	JTSS3200X2-1213	Scale		1
14	TS-1522031	Socket Set Screw	M5x10	4
15	JTSS3200X2-1215	Scale		1
16	ST040200	Tap Screw	#8x3/8"	4
17	TS-2361081	Lock Washer	M8	2
18	TS-1504051	Socket Head Cap Screw	M8x25	2
19	JTSS3200X2-1219	T-Nut Block		1
20	TS-2360121	Flat Washer	M12	1
21	TS-1550061	Flat Washer	M8	3
22	TS-1522011	Socket Set Screw	M5x6	2
23	TS-1550061	Flat Washer	M8	1
24	TS-1540061	Hex. Nut	M8	2

13.0 Exploded Drawing of Crosscut Table Extension Fence Assembly

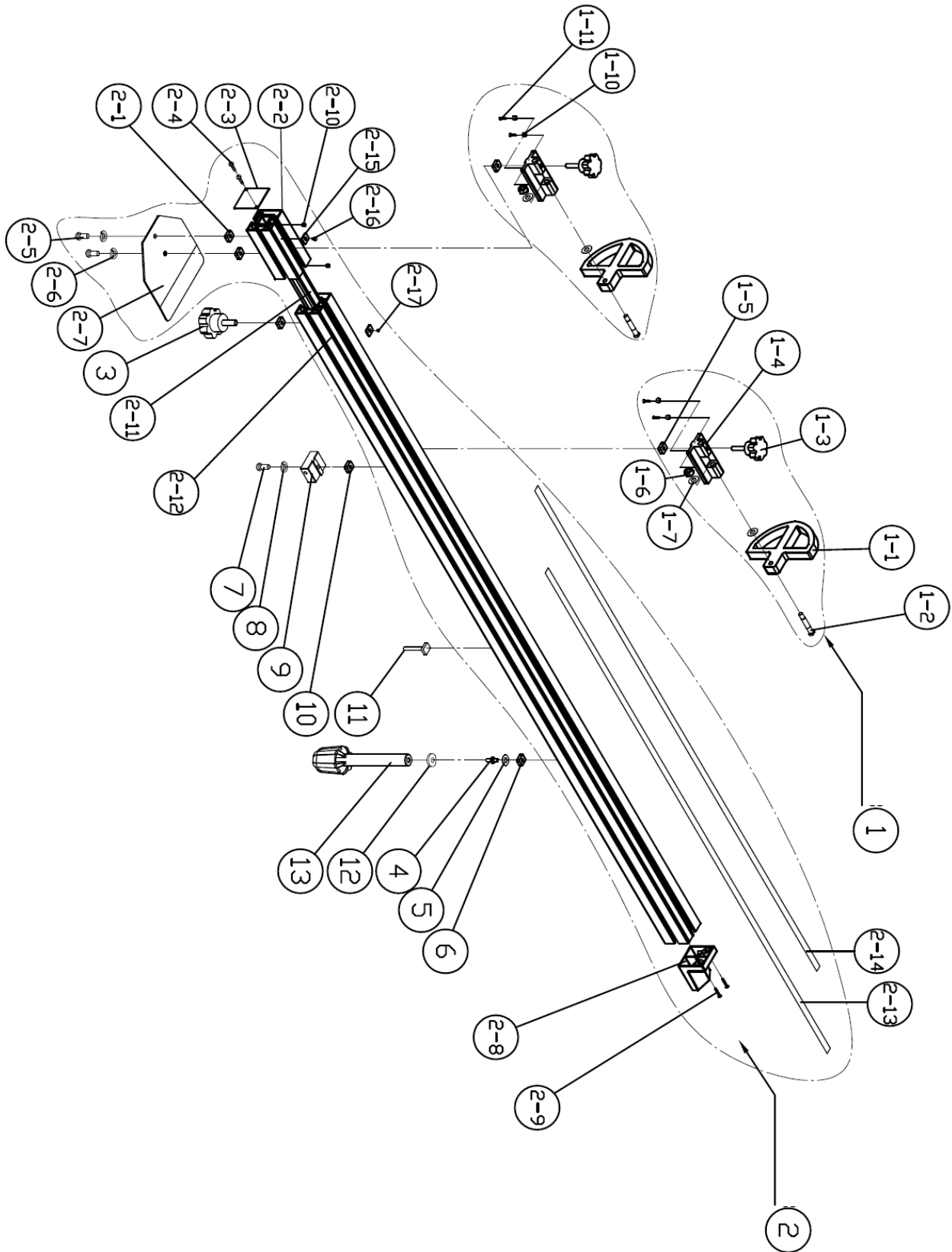

13.1 Parts List of Crosscut Table Extension Fence Assembly

Index No.	Part No.	Description	Size	Qty.
1	JTS700-1022	Flip Stop Assembly		2
1-1	JTSS3200X2-1301-1	Flip Stop		1
1-2	JTSS3200X2-1301-2	Flip Stop Pivot Shaft		1
1-3	JTSS3200X2-1301-3	Knob Screw	M8x40Lx1.25P	1
1-4	JTSS3200X2-1301-4	Flip Stop Bracket		1
1-5	JTS700-1021	T-Nut	M8x1.25P	1
1-6	TS-1541041	Hex. Nut Nylon Lock	M10	1
1-7	JTSS3200X2-1301-7	Copper Washer	Ø11xØ18x0.5 thk.	2
1-10	JTSS3200X2-1301-10	Ring Spacer		2
1-11	JTSS3200X2-1301-11	Cup Screw	M3x12	2
2	JTSS3200X2-1302	Extension Fence Assembly		1
2-1	JTS700-1021	T-Nut	M8x1.25P	2
2-2	JTSS3200X2-1302-2	Extension Fence		1
2-3	JTSS3200X2-1302-3	Extension Fence End Cover Plate		1
2-4	ST040200	Tap Screw	M4x10	2
2-5	TS-2248162	Socket Button Head Screw	M8x16	2
2-6	TS-2361081	Lock Washer	M8	2
2-7	JTSS3200X2-1302-7	Extension Fence Locate Plate		1
2-8	JTS700-206424	Extension Fence End Plug		1
2-9	TS-1532032	Pan Head Screw	M4x10	2
2-10	TS-1523011	Socket Set Screw	M6x6	2
2-11	JTSS3200X2-1302-11	Extension Fence Connector Tube		1
2-12	JTSS3200X2-1302-12	Crosscut Fence		1
2-13	JTSS3200X2-1302-13	Extension Fence Scale	0~2000 mm	1
2-14	JTSS3200X2-1302-14	Extension Fence Scale	1720~3420 mm	1
2-15	JTSS3200X2-1302-15	Nut		2
2-16	JTS700-SR050120	Hex. Socket Screw	M5x6	1
2-17	JTS700-SS050100	Socket Set Screw	M5x5	1
3	JTS700-1008	Knob Screw	M8x25Lx1.25P	1
4	JTSS3200X2-1304	Pivot Shaft		1
5	JTSS3200X2-1305	Fiber Flat Washer	M10	1
6	JTS700-1021	T-Nut	M8x1.25P	1
7	TS-1504071	Socket Head Cap Screw	M8x35	1
8	TS-2361081	Lock Washer	M8	1
9	JTSS3200X2-1309	T-Block		1
10	JTS700-1021	T-Nut	M8x1.25P	2
11	JTSS3200X2-1311	T-Bolt	M8×35Lx1.25P	1
12	TS-1550061	Flat Washer	M8	1
13	JTSS3200X2-1313	Connector Tube Lock Knob		1

14.0 Exploded Drawing of Rip Fence Assembly

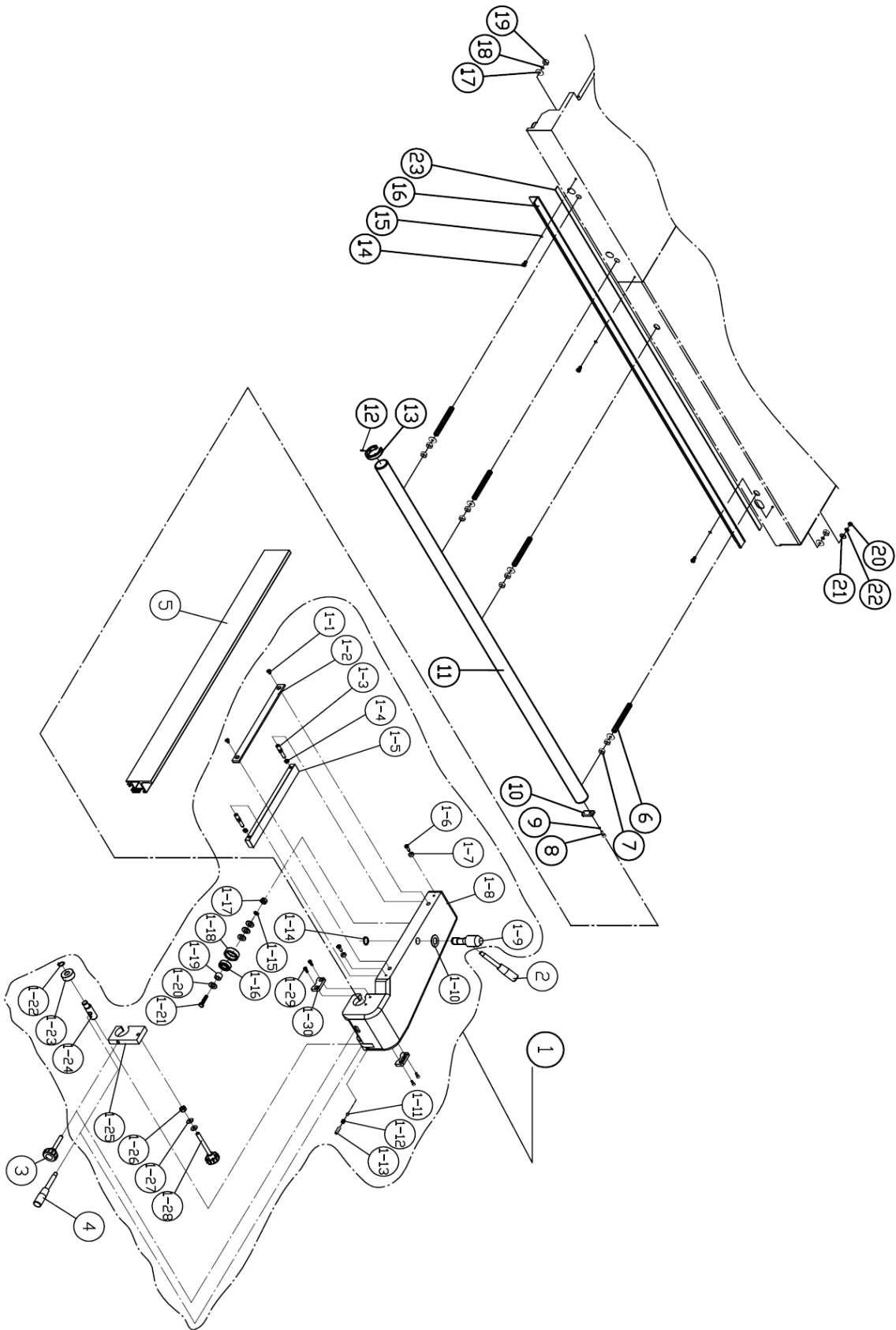

14.1 Parts List of Rip Fence Assembly

Index No.	Part No.	Description	Size	Qty.
1	JTSS3200X2-1401	Rip Fence Head Assembly		1
1-1	JTS700-SI069400	Counter Sunk Screw	M6x16	2
1-2	JTS700-206433	Clamp Lock Plate		1
1-3	JTS700-203193	Eccentric Shaft		2
1-4	TS-1541031	Hex. Nut Nylon Lock	M8	2
1-5	JTS700-200875	Rip Fence Seat Plate		1
1-6	TS-1482031	Hex. Cap Screw	M6x16	2
1-7	JTS700-203179	Eccentric Ring		2
1-8	JTS700-206422	Rip Fence Casting Seat		1
1-9	JTS700-203213	Fence Sliding Lock Knob (Eccentric Shaft)		1
1-10	TS-1550111	Flat Washer	M20	1
1-11	JTS700-994181	Steel Ball	Ø8	1
1-12	JTS700-150099	Compression Spring		1
1-13	TS-1525011	Socket Set Screw	M10x10	1
1-14	JTS700-RS200000	Int. Retaining Ring	20 mm	1
1-15	TS-2361081	Lock Washer	M8	1
1-16	BB-6202ZZ	Ball Bearing	6202ZZ	1
1-17	TS-1540061	Hex. Nut	M8	1
1-18	JTS700-203356	Busing Ring	M8	1
1-19	JTS700-206435	Pad Ring		1
1-20	TS-1550061	Flat Washer	M8	4
1-21	TS-149006	Hex. Cap Screw	M8x35	1
1-22	JTS700-RS150000	Int. Retaining Ring	15 mm	1
1-23	JTS700-203649	Bushing Ring		1
1-24	JTS700-203650	Handle shaft		1
1-25	JTS700-206428	Rip Fence Rail Bracket		1
1-26	TS-1541041	Hex. Nut Nylon Lock	M10	1
1-27	TS-1550071	Flat Washer	M10	2
1-28	JTS700-205114	Adjust Knob Screw	M10x110	1
1-29	TS-1503021	Socket Head Cap Screw	M6x10	4
1-30	JTS700-205822	Way Wiper (Scraper)		2
2	JTS700-200884	Fence Sliding Lock Knob Handle		1
3	JTS700-206432	Knob Screw	M10x55Lx1.5P	1
4	JTS700-200884	Lock Down Handle		1
5	JTS700-205663	Rip Fence Profile	1 M	1
6	JTSS3200X2-1406	All Thread Stud	M12x115Lx1.75P	4
7	TS-1540081	Hex. Nut	M12	8
8	TS-1504031	Socket Head Cap Screw	M8x16	1
9	TS-2361081	Lock Washer	M8	1
10	JTSS3200X2-1410	Rip Fence Rail End Plate		1
11	JTSS3200X2-1411	Rip Fence Round Rail		1
12	TS-1523031	Socket Set Screw	M6x10	1
13	JTSS3200X2-1413	Rip Fence Stop Ring		1
14	TS-2246122	Socket Head Button Screw	M6x12	3

15	TS-1550041	Flat Washer	M6	3
16	JTSS3200X2-1416	Scale Rail		1
17	WF132225	Washer	M13x22x2.5 thk.	8
18	TS-2361121	Lock Washer	M12	4
19	TS-1540081	Hex. Nut	M12	4
20	TS-1540041	Hex. Nut	M6	1
21	TS-1550041	Flat Washer	M6	1
22	TS-2361061	Lock Washer	M6	1
23	JTSS3200X2-1423	Rip Fence Scale		1

15.0 Exploded Drawing of Sliding Table Assembly

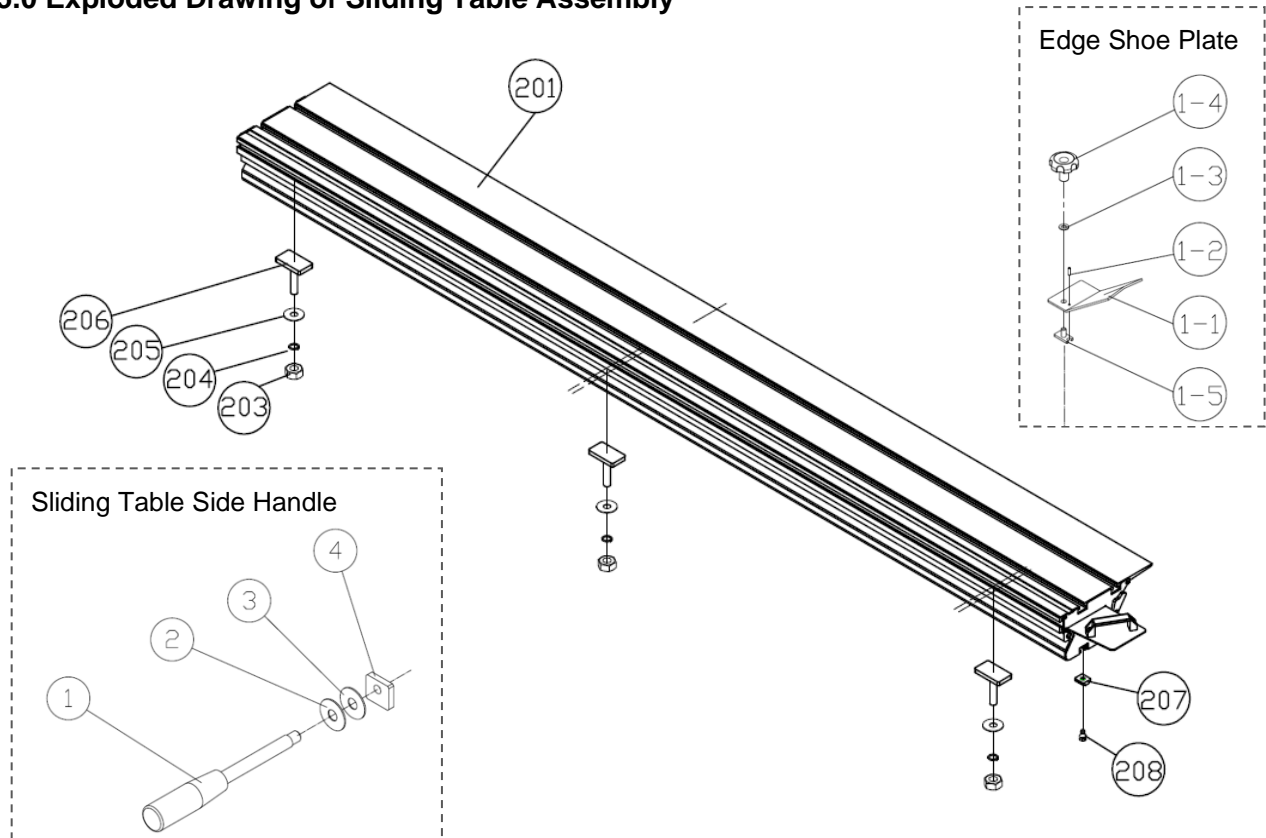

15.1 Parts List of Sliding Table

Index No.	Part No.	Description	Size	Qty.
	QY2360320E-A	JTSS3200X2 Sliding Table Assembly	3200 mm	1
201	JTSS3200X2-1501-201	Sliding Table		1
203	NH121900	Hex. Nut	M12x1.75P	3
204	TS-2361121	Lock Washer	M12	3
205	TS-2360121	Flat Washer	M12	3
206	JTSS1600x2-1505	T-Bolt	M12x60x1.75P	3
207	JTS700-325	T-Nut (Locate Plate)		1
208	TS-1506021	Socket Head Cap Screw	M12x25x1.75P	1
	JTSS3200X2-AB200939	Sliding Table Side Handle Assembly		1
1	JTSS3200X2-1501	Handle		1
2	TS-2360121	Flat Washer	M12	1
3	JTSS3200X2-1503	Plastic Washer	M13xØ25x2 thk.	1
4	JTSS3200X2-1504	T-Nut	M12x1.75P	1
	JTSS3200X2-AB201830	Edge Shoe Assembly		1
1-1	JTSS3200X2-1501-1	Edge Shoe Plate		1
1-2	JTSS3200X2-1501-2	Pin	Ø5xØ18	1
1-3	TS-1550071	Flat Washer	M10	1
1-4	JTSS3200X2-1501-4	Knob Screw	M10	1
1-5	JTSS3200X2-1501-5	T-Nut	M10x1.5P	1

15.2 Exploded Detail Drawing of Sliding Table Assembly

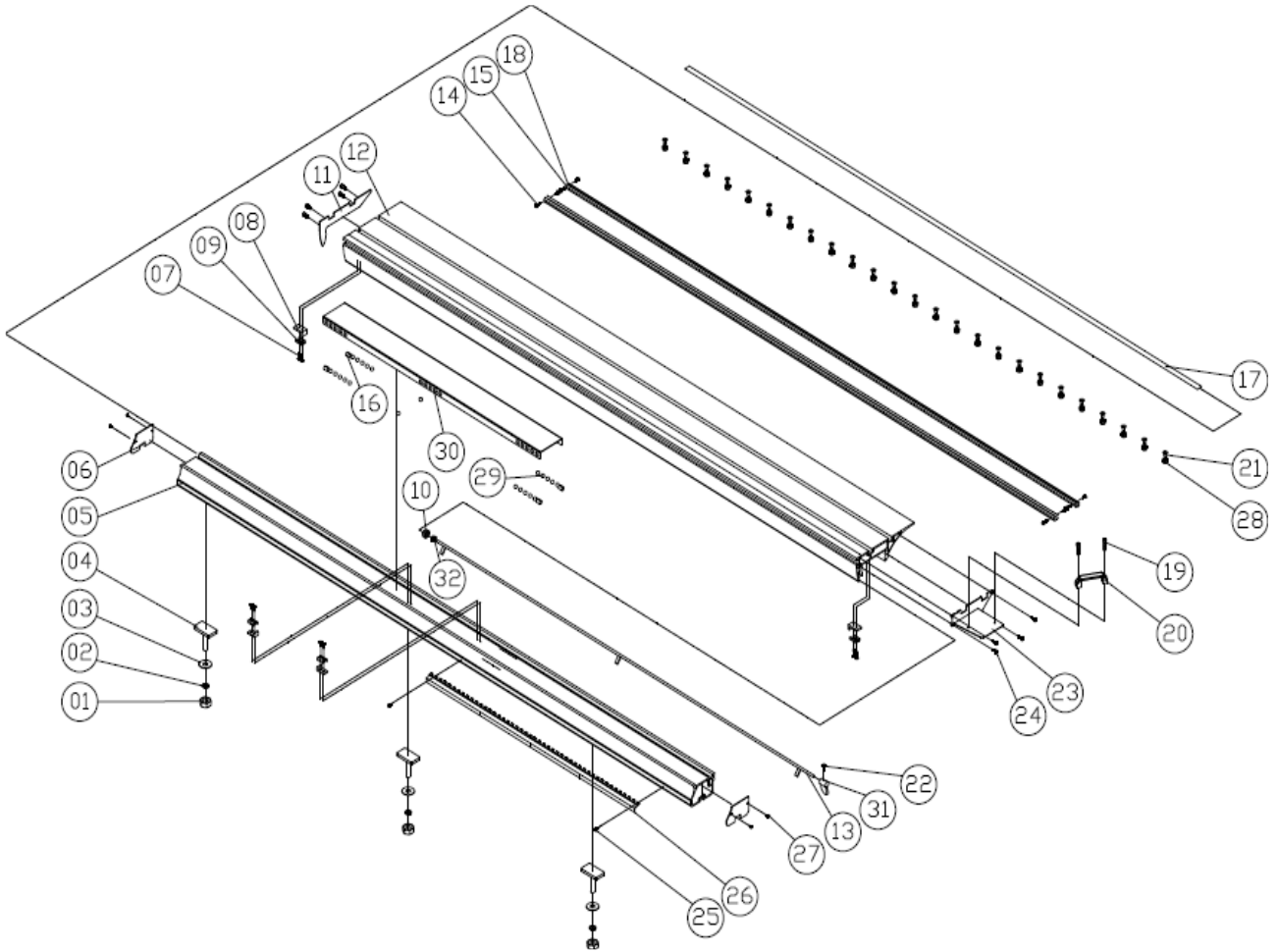

15.3 Parts List of Detail Drawing of Sliding Table Assembly

Index No.	Part No.	Description	Size	Qty.
1	NH121900	Hex. Nut	M12x1.75P	3
2	TS-2361121	Lock Washer	M12	3
3	TS-2360121	Flat Washer	M12	3
4	JTSS1600x2-1505	T-Bolt	M12x60x1.75P	3
5	2360320E-2	Sliding Table Bottom Base	3200mm	1
6	2360320E-7	Sliding Table Bottom Base Side Cover		2
7	TS-1514051	Socket Head Flat Screw	M6x30	8
8	2360320E-14	Rubber Block		4
9	2360320E-12	Locate Block Plate		4
10	2360320E-13	Lock Rod End Cap		1
11	2360320E-9	Sliding Table Left Side Cover		1
12	2360320E-1	Sliding Table	3200mm	1
13	2360320E-5	Locate Lock Rod		1
14	TS-2246102	Socket Head Button Screw	M6x10	8
15	2360320E-11	Sliding Table Way		8
16	2360320E-15	Wool Pad		4
17	2360320E-8	Cover Strip		1
18	2360320E-4	Way Adhesive Strip		8
19	TS-1504021	Socket Head Cap Screw	M8x12	2
20	200959	Handle		1
21	SM100400	Socket Head Flat Screw	M10x20	25
22	TS-2245102	Socket Head Button Screw	M5x10	1
23	2360320E-6	Sliding Table Right End Plate		1
24	TS-2246122	Socket Head Button Screw	M6x12	8
25	TS-2246162	Socket Head Button Screw	M6x16	2
26	2360320E-3	Teeth Locate Lock Plate		4
27	ST040200	Tape Screw	M4x10	4
28	TS-1541041	Hex. Nut Nylon Lock	M10	25
29	2360320E-17	Hardened Steel Ball	φ 16.6	22
30	2360320E-16	Slide Plate		1

16.0 Exploded Drawing of Saw Blade Guard Assembly

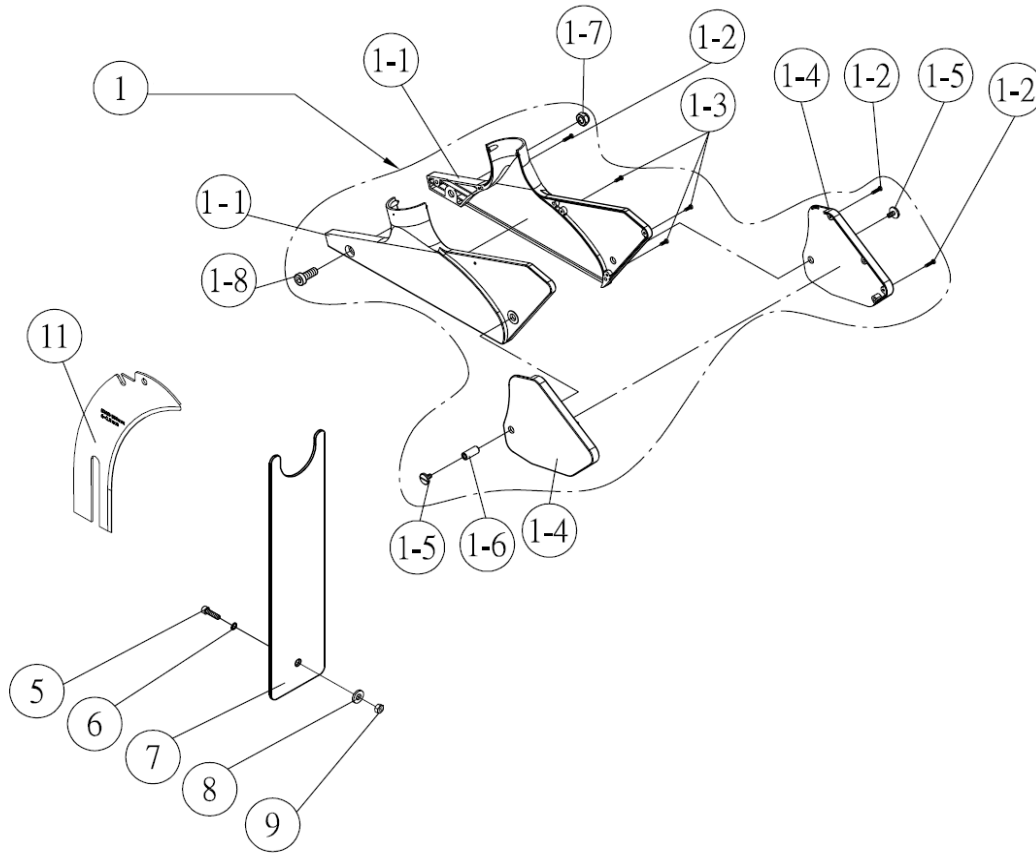

16.1 Parts List of Saw Blade Guard Assembly

Index No.	Part No.	Description	Size	Qty.
1	JTSS3200X2-1601	Blade Guard Assembly		1
1-1	JTSS3200X2-1601-1	Main Blade Guard		1
1-2	ST029404	Tap Screw	M3x16	3
1-3	ST029304	Tap Screw	M3x12	3
1-4	JTSS3200X2-1601-4	Scoring Blade Guard		1
1-5	203110	Scoring Guard Pivot Screw	M5x10	2
1-6	JTSS3200X2-1601-6	Pivot Sleeve		1
1-7	TS-1541041	Hex. Nut Nylon Lock	M10	1
1-8	205162	Socket Head Cap Screw (special size)	M10x25	1
5	TS-1505031	Socket Head Cap Screw	M10x25	1
6	TS-2361101	Lock Washer	M10	1
7	JTS700-206422	Dust Hose Support Plate		1
8	TS-1550071	Flat Washer	M10	1
9	TS-1541041	Hex. Nut Nylon Lock	M10	1

11JTSS3200X2-1611Riving Knife 1

17.0 Exploded Drawing of Hold-Down Assembly

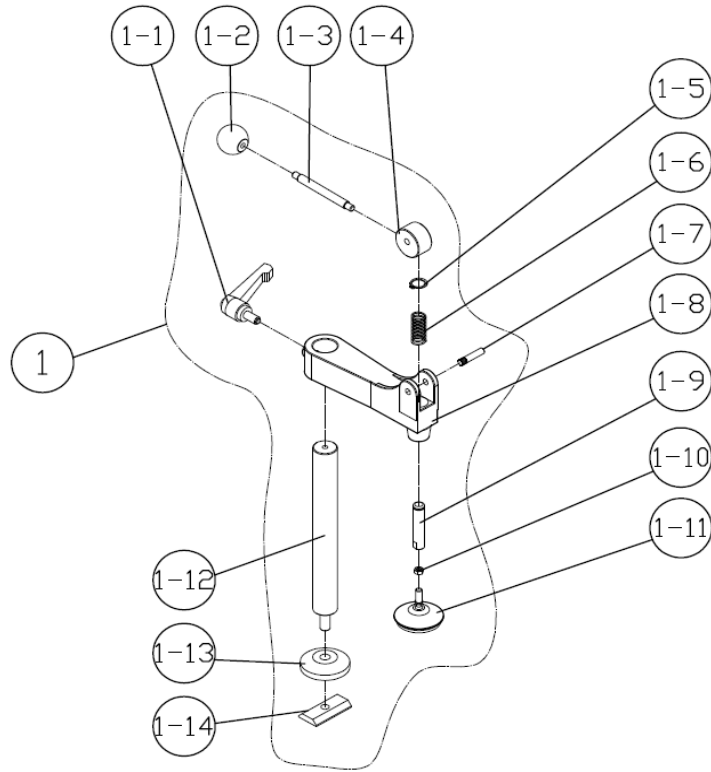

17.1 Parts List of Hold-Down Assembly

Index No.	Part No.	Description	Size	Qty.
1	JTSS3200X2-1701	Hold Down-Press Assembly		1
1-1	JTSS3200X2-1701-1	L Lock Handle screw		1
1-2	JTSS3200X2-1701-2	Down-Press Ball Handle		1
1-3	JTSS3200X2-1701-3	Down-Press Handle bar		1
1-4	JTSS3200X2-1701-4	Down Press Cam		1
1-5	JTSS3200X2-1701-5	Ext. Retaining Ring	14 mm	1
1-6	JTSS3200X2-1701-6	Down-Press Spring		1
1-7	JTSS3200X2-1701-7	Down-Press Cam shaft		1
1-8	JTSS3200X2-1701-8	Down-Press Bracket		1
1-9	JTSS3200X2-1701-9	Push Plate Arbor		1
1-10	TS-0570021	Hex. Nut	5/16-18	1
1-11	JTSS3200X2-1701-11	Push Plate		1
1-12	JTSS3200X2-1701-12	Down-Press Bracket Arbor		1
1-13	JTSS3200X2-1701-13	Down-Press Bushing		1
1-14	JTSS3200X2-1701-14	Down-Press Fix Block		1

18.0 Exploded Drawing of Miter Gauge Assembly

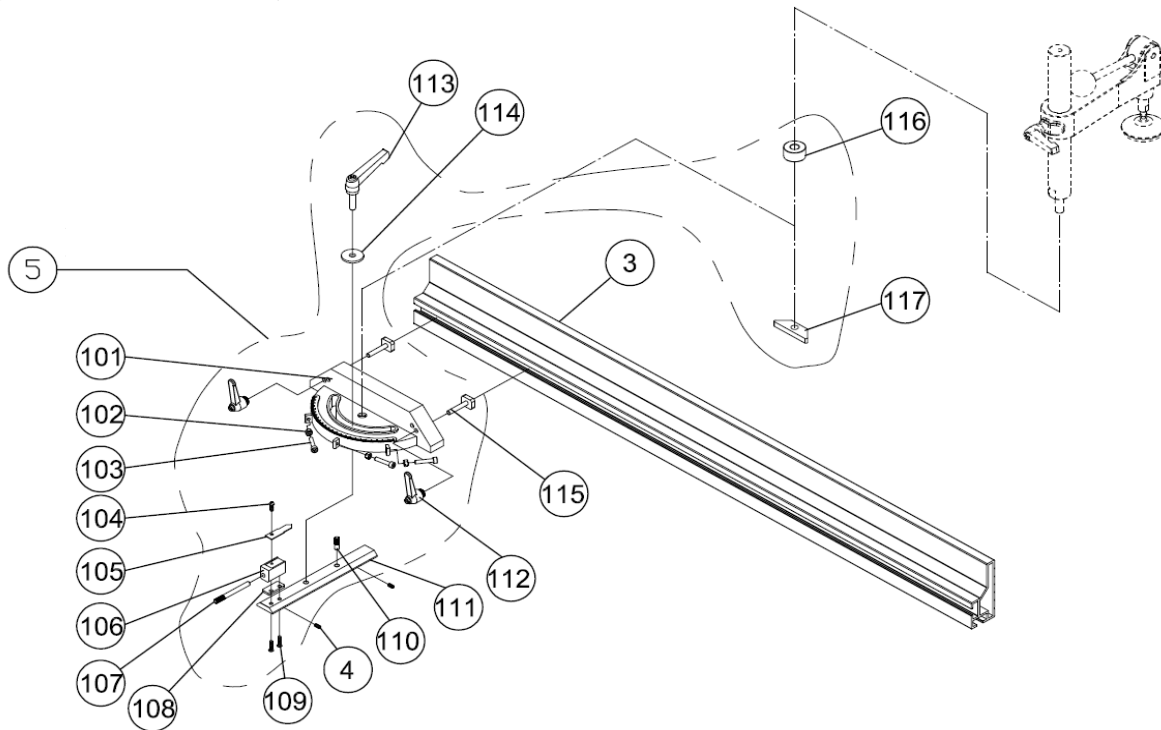

18.1 Parts List of Miter Gauge Assembly

Index No.	Part No.	Description	Size	Qty.
3	JTSS3200X2-1803	Fence Profile		1
4	JTSS3200X2-1804	Spring Plungers with Ball	M4x9	2
5	JTSS3200X2-1805	Miter Gauge Assembly		1
101	JTSS3200X2-1805-1	Miter Gauge Main Body		1
102	TS-1540031	Hex. Nut	M5	3
103	TS-1502061	Socket Head Cap Screw	M5x25	3
104	TS-1532042	Pan Head Screw	M4x12	1
105	JTSS3200X2-1805-5	Pointer		1
106	JTSS3200X2-1805-6	Fix Block		1
107	JTSS3200X2-1805-7	Stop Pin		1
108	JTSS3200X2-1805-8	End Block	3 mm thk.	1
109	TS-1532052	Pan Head Bolt	M4x16	2
110	JTSS3200X2-1805-10	Miter Gauge Shaft		1
111	JTSS3200X2-1805-11	Guide Bar		1
112	JTSS3200X2-1805-12	Adjust Handle Screw		2
113	JTSS3200X2-1805-13	L Lock Handle Screw		1
114	TS-1550061	Flat Washer	M8	1
115	JTSS3200X2-1805-15	T-Bolt		2
116	JTSS3200X2-1805-16	Down-Press Disc		1
117	JTSS3200X2-1805-17	Down-Press Locate Block		1

Circuit Diagram JTSS-3200X2...1000062T...3~400V, 50Hz

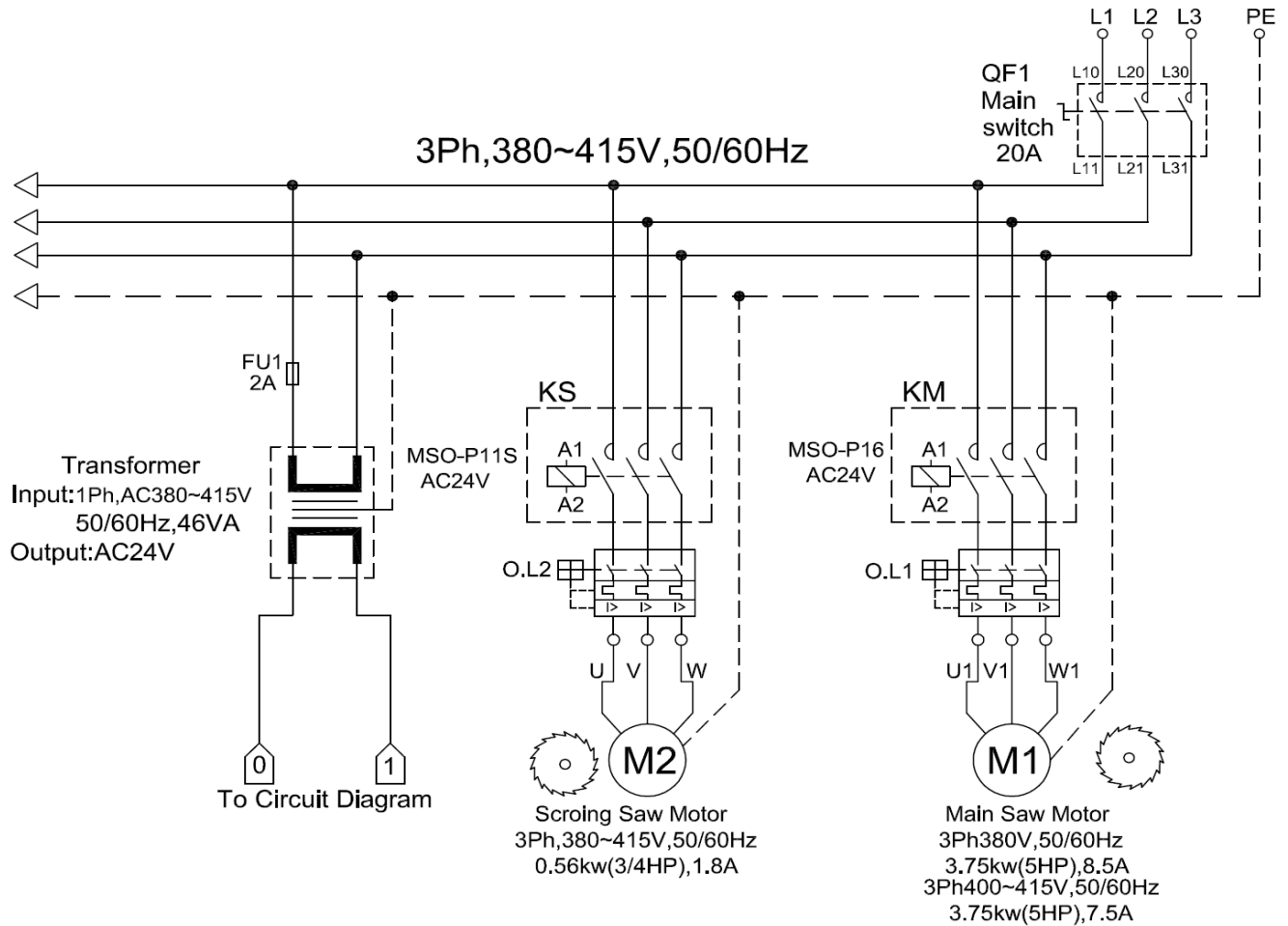

Symbol	Meaning of Symbol
L1 L2	Back Door Limit Switch Blade Cover Limit Switch
O.L1 O.L2	Main Saw Blade Motor Overload Scoring Saw Blade Motor Overload
EM1 EM2	Panel Emergency Stop Switch Machinery Emergency Stop Switch
S1 S2 S3 S4	Main Saw Stop Button Switch Scoring Saw Stop Button Switch Main Saw Start Button Switch Scoring Saw Start Button Switch
HL	Power Light (AC 24V)
M1 M2	Main Saw Blade Motor Scoring Saw Blade Motor
KM KS	Magnet Contactor for Main Saw Blade motor Magnet Contactor for Scoring Saw Blade motor
FU	Fuse

TO Transformer output
(Line Number 0,1)

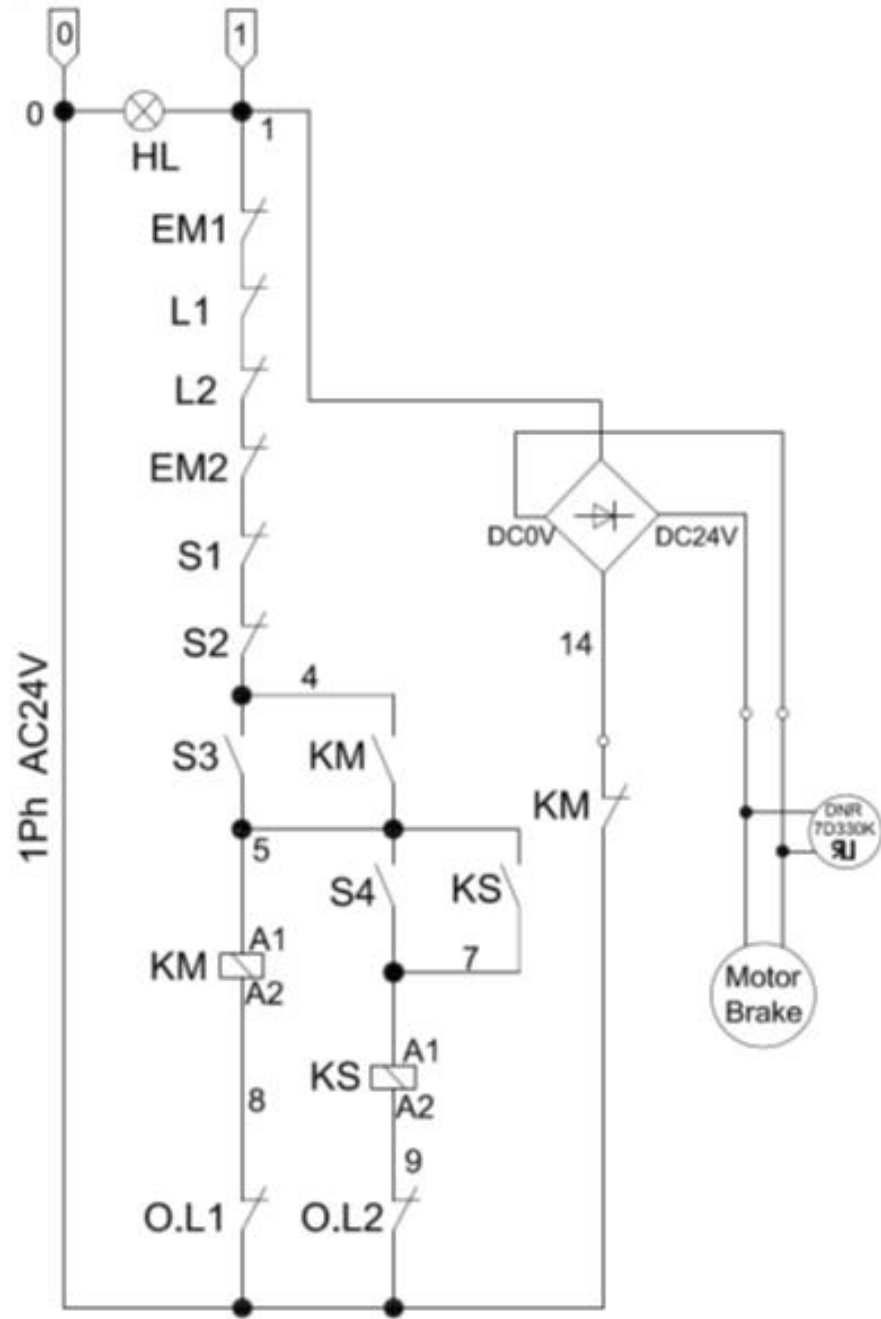

Appendix:

Parts List of Electric Appliance Case

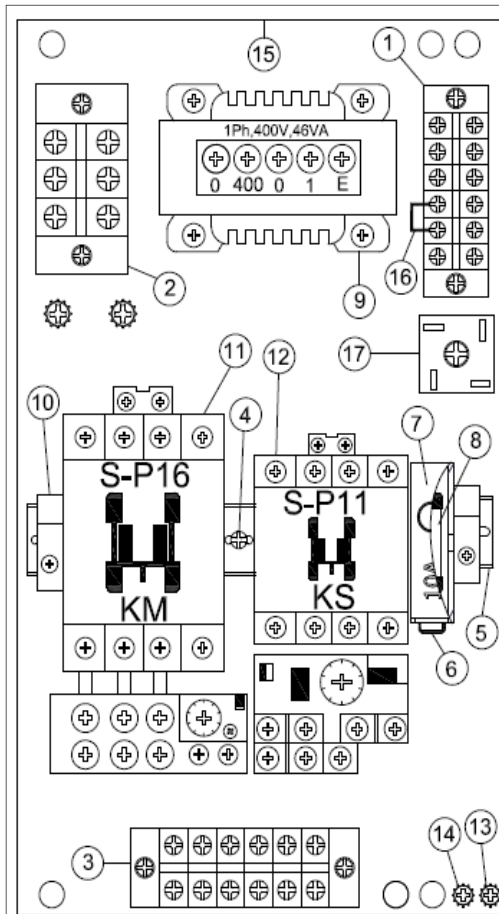

Item	Part No.	Part Name	Specification	Q'TY
1	994892	Terminal	TB15-6P	1
2	994893	Terminal	TB25-3P	1
3	994894	Terminal	TB25-6P	1
4	SP040200	Pan head screw	M4x10L	8
5	205186	DIN rail	Omega type	1
6	205416	Fuse holder	1P 30mm	1
7	205416-02	Fuse holder cover with light	1P 30mm AC light	1
8	994895	Fuse	30mm 2A	1
9	994839	Transformer	Input : 380~415V 50/60Hz Output : 24V ,Cap.:46VA	1
10	203756	DIN rail end bracket	ZGX TBR-F	2
11	994915	Magnetic switch	MSO-P16S AC24V, TH-20SPP 9A(7~11A)	1
12	994774	Magnetic switch	MSO-P11S AC24V, TH-12S 1.7A(1.3~2.1A)	1
13	SF049200	Pan head screw (W/Flange)	M4x8L	4
14	WE040000	Star washer	M4	8
15	200867A-1	Circuit plate		1
16	205393	Terminal jumper	2P	1
17	205407	Bridge rectifier	KBPC2506 600V	1