

JET

JCDC-3.0

Cyclone Dust Collector

JCDC-3.0.....717530T3~400V, 50Hz

PARTS LIST

JPW (Tool) AG
Tämperlistr. 5
CH-8117 Fällanden
Switzerland
Phone +41 44 806 47 48
Fax +41 44 806 47 58

www.jettools.com

P-717530T

2016-04



Parts Breakdown for JCDC-3.0 Cyclone Dust Collector

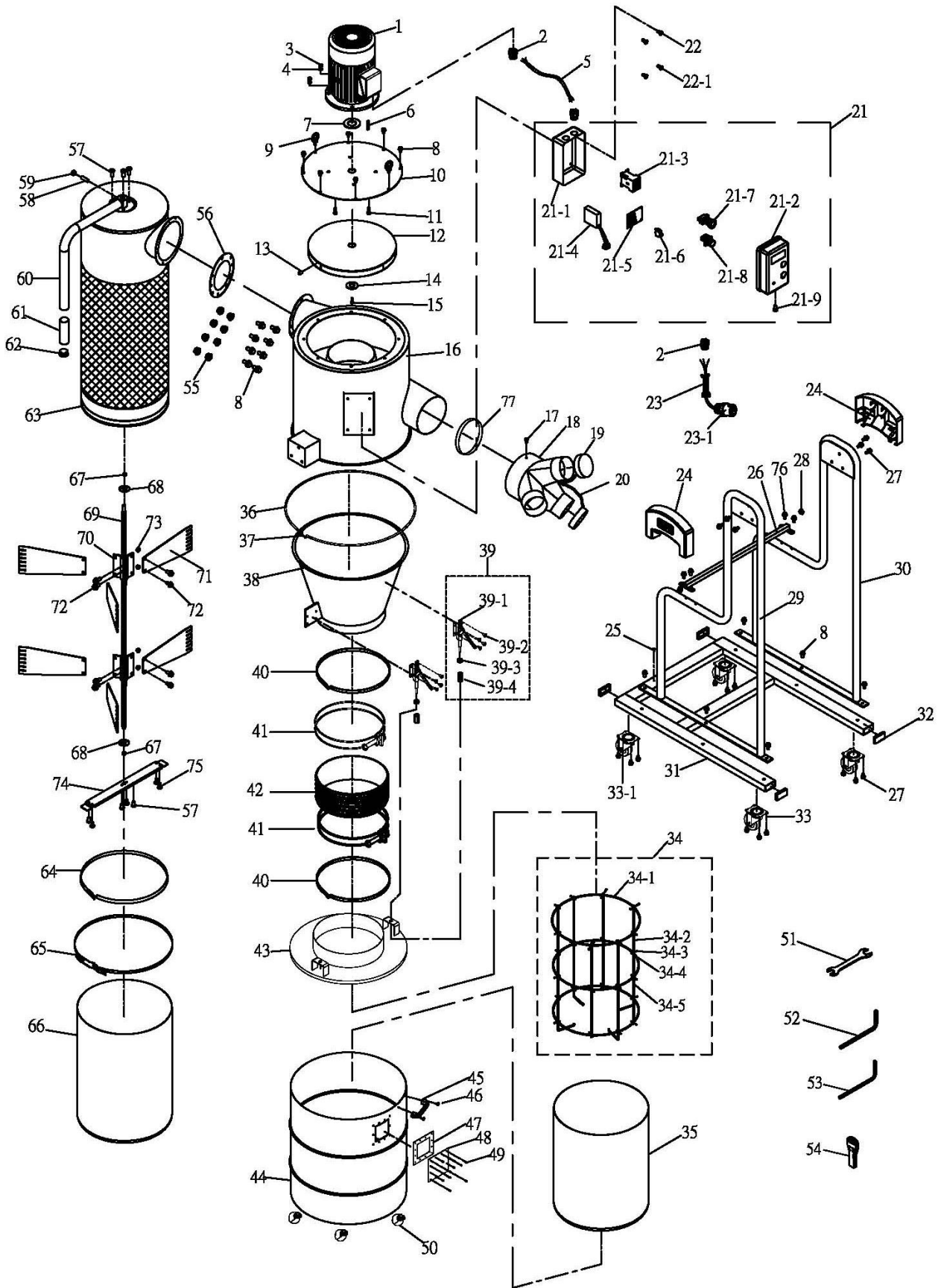

Parts List for JCDC-3.0 Cyclone Dust Collector

Index No.	Part No.	Description	Size	Qty.
1	502-B868	Motor	3HP/380V/50HZ/3PH	1
	502-B868	Motor (UK)	3HP/400V/50HZ/3PH	1
	JCDC1.5-01FC	Fan Cover (not shown)		1
	JCDC1.5-01CF	Cooling Fan (not shown)		1
2	JCDC1.5-02	Strain Relief	M20-13B/PG20	3
3	TS-0570021	Hex Nut	5/16"	4
4	TS-0720081	Lock Washer	5/16"	4
5	503-J343	Motor Cord	1.5mm ² x4Cx75CM	1
6	JCDC2-06	Key	7 x 7 x 25	1
7	JCDC2-07	Rubber Seal		1
8	JCDC1.5-07	Hex Flange Head Screw	5/16" x 3/4"	20
9	JCDC1.5-08	Eye Bolt	5/16"	2
10	JCDC3-10	Motor Plate		1
11	TS-0051051	Hex Cap Screw	5/16" x 1"	4
12	JCDC3-12	Impeller	Dia. 15"	1
13	TS-0271071	Socket Set Screw	3/8" x 3/4"	1
14	JCDC1.5-14	Lock Washer	Exclusive	1
15	JCDC1.5-15	Socket Head Cap Screw (Left Thread)	M6 x 20	1
16	JCDC3-16	Intake Barrel		1
17	5513357	Mach Screw, Pan HD, Phillips	3/16" x 3/8"	1
18A	JCDC3-18A	Inlet Adaptor Assembly (Index #18,19,20)		1
18	JCDC3-18	Inlet Adaptor	8" x (3) 4"	1
19	JCDC1.5-20	Inlet Adaptor Cap	4"	2
20	JCDC1.5-19	Chain		2
21	501-F109	Switch Assembly (Index # 21-1 thru 21-9)		1
21-1	JCDC2-21-1	Switch Box – Lower Cover		1
21-2	JCDC2-21-2	Switch Box – Upper Cover		1
21-3	JCDC2-21-3	Contactor	MA-09	1
21-4	JCDC2-21-4	Remote Control Receiver		1
21-5	JCDC2-21-5	Circuit Board		1
21-6	501-O002	Overload Protector	5A	1
21-7	JCDC2-21-7	Push Button Switch - Start	Green	1
21-8	JCDC2-21-8	Emergency Stop Switch		1
21-9	5711571	Mach Screw, Pan HD, Phillips	3/16" x 1/4"	1
22	JCDC2-22	Mach Screw, Pan HD, Phillips w/ Flange	3/16" x 3/8"	2
22-1	5513357	Mach Screw, Pan HD, Phillips	3/16" x 3/8"	2
23	503-J337	Power Cord	1.25mm ² x5Cx3.6M	1
23-1	501-D008	3PH/400V CE Plug	P-551	1
24	JCDC2-24	Side Cap		2
25	5711571	Mach Screw, Pan HD, Phillips	3/16" x 1/4"	1
26	JCDC3-26	Connecting Square Tube	19 x 19 x 735	1
27	JCDC1.5-25	Hex Flange Head Screw	5/16" x 1/2"	22
28	JCDC1.5-24	Tube Plug	19 x 19	2
29	JCDC3-29	Stand - Left		1
30	JCDC3-30	Stand - Right		1
31	JCDC3-31	Base		1
32	JCDC3-32	Tube Plug	75 x 25	4
33	JCDC3-33	Swivel Caster	Dia. 3"	2
33-1	JCDC3-33-1	Swivel Caster w/ Brake	Dia. 3"	2
34	JCDC3-34	Bag Frame Kit (Index # 34-1 thru # 34-5)		1
34-1	JCDC3-34-1	Hoop	6T	3
34-2	JCDC3-34-2	Bag Frame Support - Long	7mm	4
34-3	TS-1540011	Hex Nut	M3	24

34-4	JWL1221VS-314	Mach Screw, Pan HD, Phillips	M3 x 12	24
34-5	JCDC3-34-5	Bag Frame Support -Short	7mm	4
35	717531	Drum Collection Bag for JCDC-3 (pkg. of 5)	980 x 1200 /mm	1
36	JCDC2-35	Clamp	Dia. 500 mm	1
37	TS-0050111	Hex Cap Screw	1/4" x 2-1/2"	1
38	JCDC2-37	Cyclone Funnel		1
39	JCDC1.5-36	Quick Lever Assembly (Index # 39-1 thru # 39-4)		2
39-1	JCDC1.5-36-1	Quick Lever		2
39-2	5712561	Mach Screw, Pan HD, Phillips	M5 x 8	8
39-3	TS-0570031	Hex Nut	3/8"	2
39-4	JCDC1.5-36-4	Long Nut	3/8"	2
40	JCDC2-39	Foam Tape	L970 x W30 x T1 /mm	2
41	JCDC2-40	Hose Clamp	12-1/2"	2
42	JCDC2-41	Hose	Dia.12"	1
43	JCDC3-43	Collection Drum Lid		1
44A	JCDC3-44A	Collection Drum Assembly (#44 thru 50)		1
44	JCDC3-44	Collection Drum		1
45	JCDC1.5-42	Handle		1
46	TS-081F031	Mach Screw, Flat HD, Phillips	1/4" x 1/2"	2
47	JCDC1.5-44	Rubber Pad		1
48	JCDC1.5-45	PC Plate		1
49	JCDC1.5-46	Rivet	4-2	12
50	JCDC2-49	Swivel Caster	Dia. 2"	4
51	SWSS3-201	Open End Wrench	10-12 mm	1
52	TS-152705	Hex Wrench	4mm	1
53	TS-152706	Hex Wrench	5mm	1
54	JCDC2-53	Remote Control Transmitter	RF	1
		Battery (not shown)	AAA, 1.5V	2
55	TS-0561021	Hex Nut	5/16"	8
56	JCDC3-56	Gasket		1
57	JCDC1.5-52	Socket HD Button Screw	M5 x 6	6
58	TS-0270071	Socket Set Screw	5/16" x 3/4"	1
59	TS-0561021	Hex Nut	5/16"	1
60A	JCDC1.5-55A	Handle Assembly (#60,61,62)		1
60	JCDC1.5-55	Handle		1
61	JCDC1.5-56	Grip		1
62	JCDC1.5-57	Pipe Plug		1
63	JCDC3-63	Canister Filter		1
64	JCDC1.5-59	Foam Tape	L1265 x W20 x T3 /mm	1
65	JCDC1.5-60	Clamp		1
66	717511	Canister Collection Bag for JCDC (pkg. of 5)	600 x 500 /mm	1
67	JCDC1.5-62	Oil-retaining Bearing		2
68	JCDC1.5-63	Bearing Cover		2
69	JCDC3-69	Shaft		1
70	JCDC1.5-65	Fixing Block		2
71A	JCDC3-71A	Scraper Assembly (#56,67 thru 75)		1
71	JCDC1.5-66	Scraper		6
72	TS-1481031	Hex Cap Screw	M5 x 12	16
73	TS-1540031	Hex Nut	M5	12
74	JCDC1.5-69	Support Plate		1
75	5712561	Mach Screw, Pan HD, Phillips	M5 x 8	4
76	JCDC1.5-71	Hex Flange Head Screw	1/4" x 1/2"	4
77	JCDC3-77	Foam Tape	L640 x W30 x T1 /mm	1
	JCDC3-HP	Hardware Package (see sect. 5.2 for contents)		

Circuit Diagram for JCDC-3.0 Cyclone Dust Collector

JCDC-3.0717530T3~380V, 50Hz

